

Torque and Speed Sensor

Model: GTL-T17

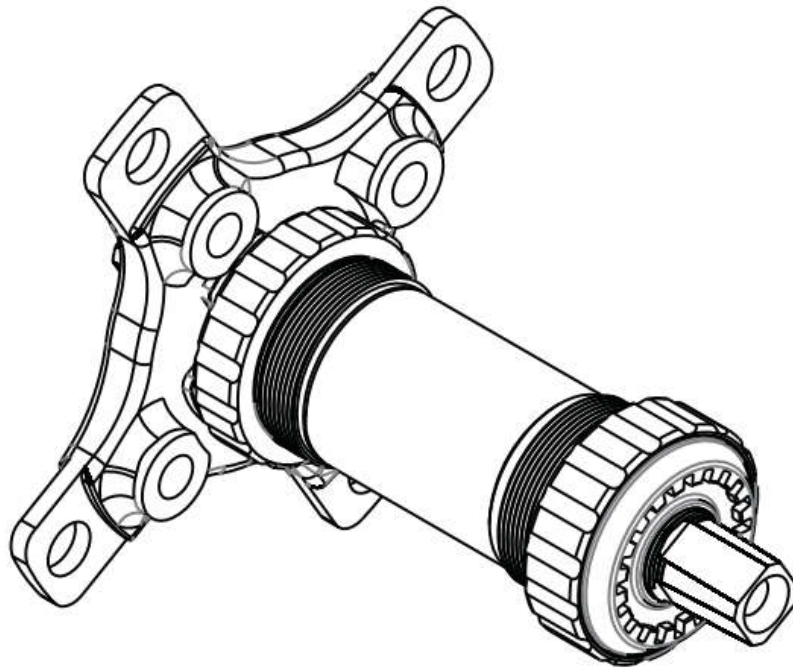

The T17 Torque and Speed Sensor (T17) is for installation in the bottom bracket (BB) of a bicycle. T17 generates a linearly steady output voltage by sensitively sensing the instant pedaling force (N.m) and signal of pedaling frequency. When the torque sensor has sensed the twisting force that came through the pedals, the sensor stably generated linearly outputs voltage between 1.5~3.0V according to the level of twisting force. Both voltage and pedaling frequency signals would then be fed back to the controller to determine the output current of the motor in a timely response, and drive the motor thence the wheel at a certain speed to assist the driver in a timely manner.

The sensor's input operating voltage is 5-15V DC, providing a stable source of energy for the sensor. The sensor will have a fixed output value of 1.5V even when foot pedals are not stressed and the bicycle is stationary.

Connector & Wiring Definitions

(Green positioning)

1. Red Power “+”
2. Black Power “-”
3. Yellow Speed Signal Output 2
4. Green Speed Signal Output 1
5. Blue No Connect
6. White Torque Signal Output

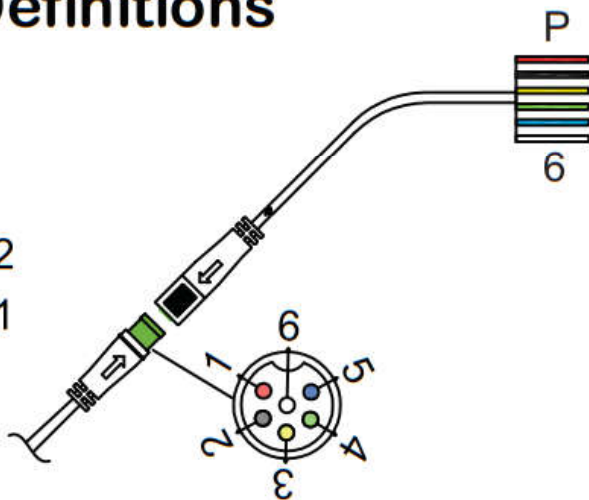

Specifications

	Items	Specifications
1	Input Voltage	5 ~ 15V DC
2	Max. Power Consumption	300 ~ 400mW
3	Pulse/ Cycle	18P x 2
4	Operation Principle	Torque
5	Reference Voltage(V_o)	$1.50 \pm 0.05V$
6	Torque Output Rang(V_{Δ})	1.50 ~ 3.0V
7	Torque Variation	0 ~ 60kg.f
8	Torque Ratio	14.7mV/ N.m
9	Ingress Protection Rating	IP 65
10	Operating Temperature	-20°C ~ +45°C
11	Storage Temperature	$\pm 0^{\circ}C \sim +60^{\circ}C$
12	Speed Signal	Speed 1: 18 square wave / rotation Speed 2: 18 square wave / rotation
13	Bottom Bracket Width(mm)	68/ 73/ 80/ 83/ 100
14	Shaft Length(mm)	150/ 155/ 162/ 165/ 182
15	Chain Line(mm)	47.5/ 50/ 53.5/ 55/ 63.5

The above CL value is based on spider C47.

Torque Sensor - - 4 arms spider

A: Appearance and Dimensions:

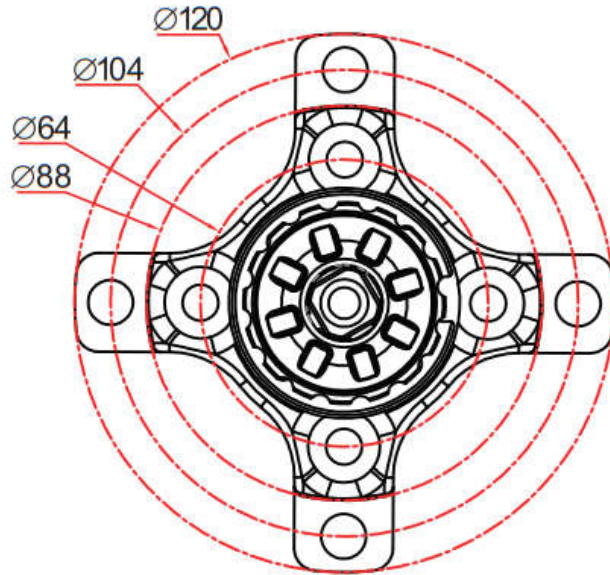

A: CL=47.5;
Fit for 44T or below.

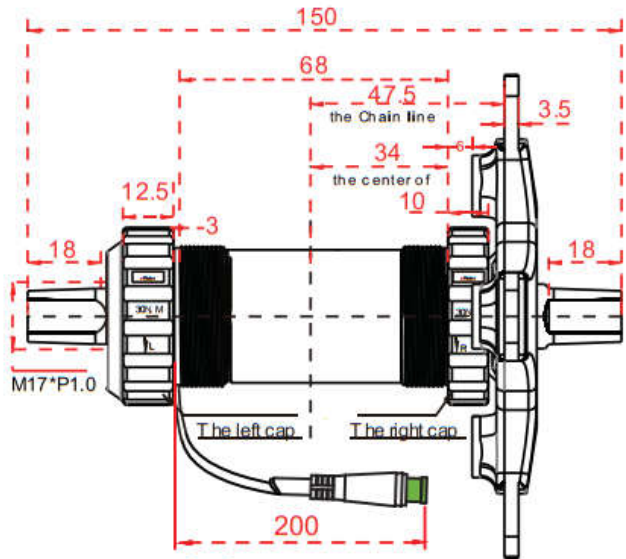
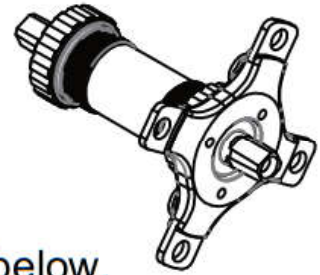

Torque Sensor - - 5 arms spider

B: Appearance and Dimensions:

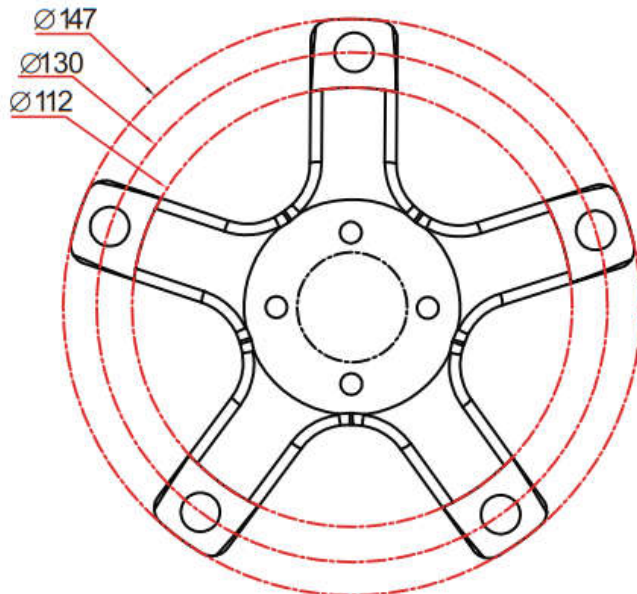

B: CL=47.5;
Fit for 48T or above.

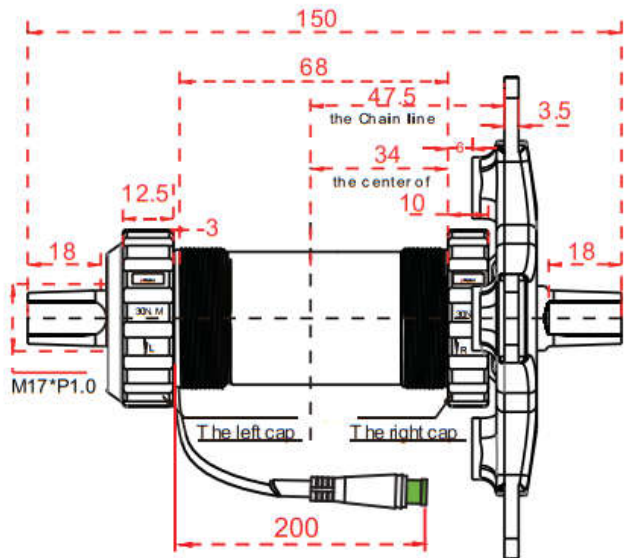

Installation Procedures

Right cup threads(Anti-tooth)
cup threads

Prior to installation: remove the wire fixing ring(e) and 8-tooth locking nut(d) before separating the rotor part of torque sensor(c).

Install and lock the right cup threads(anti-tooth)(a) into bottom bracket (30N.m).

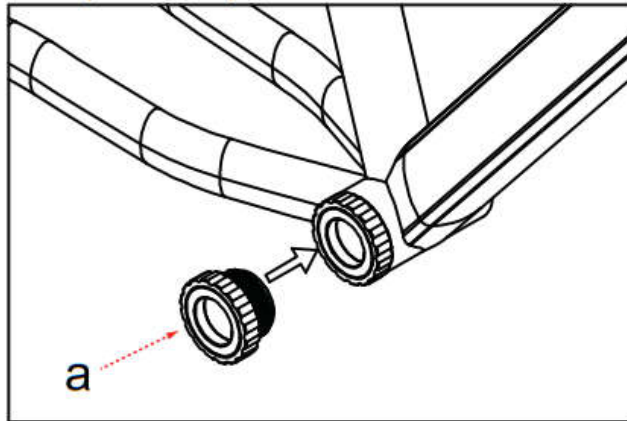

Install and lock the left cup threads(positive-tooth)(b)
into bottom bracket (30N.m).

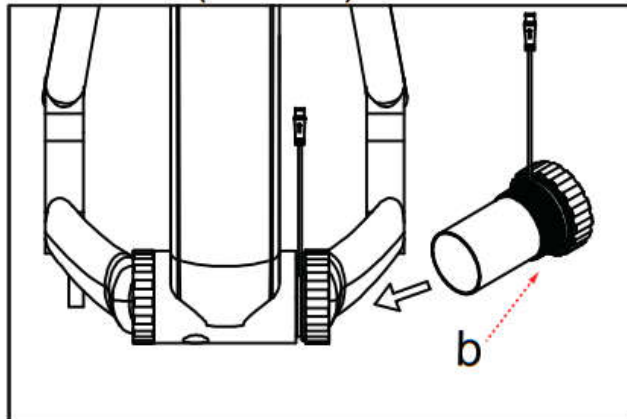

Insert the rotor part of torque sensor(c) through the left cup threads(positive-tooth)(b).

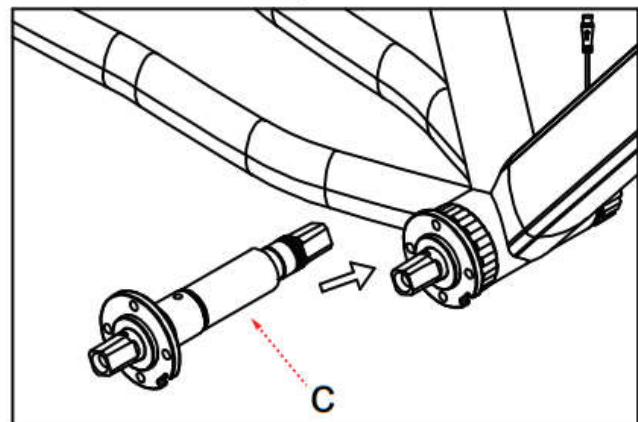

Tighten the rotor part of the torque sensor(c) with 8-tooth locking nut(d), and ensure that the rotor part is not moving around.

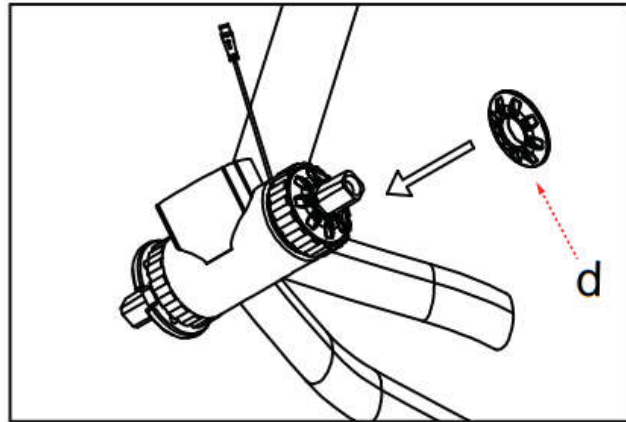

Wind the wire downward and sleeve it into the wire fixing ring(e).

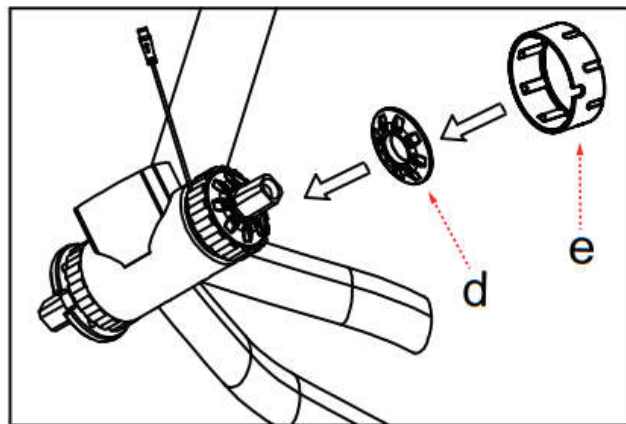

Cautions

- ① Do not attempt to disassemble or modify this product. All inspections and repair works should be carried out by qualified service personnel only. No liability will be assumed in the case of non-compliance of safety instructions and usage.
- ② To avoid cable damage, specified steps to install and uninstall the product must be followed.
- ③ During setup, the connector should be inserted by hand and pulled out by holding both sides of the wire close to the connector, pulling the wire at the sensor end must be prevented to avoid breaking the wire core.
- ④ Avoid placing eBike with this product installed close to caustic gas, and magnetic goods. Such media would adversely affect the electronic insulation properties of this product.
- ⑤ This product should NOT be used in the overload status for long duration.