

The Torque Arm V7

Installation Guide

Rev 1

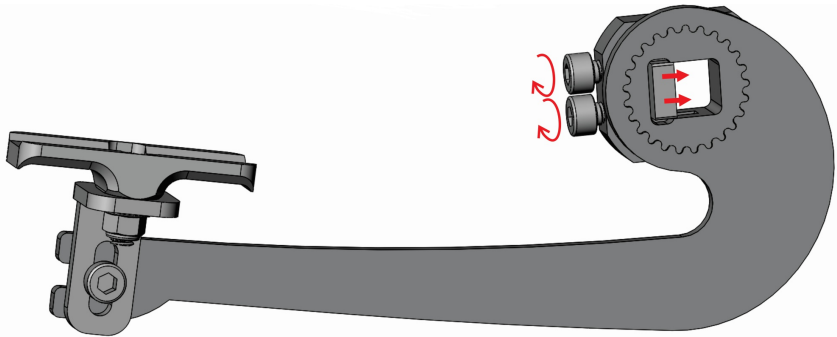

Clamping Model for Regen Hubs with 12mm Axles
Front and Rear Compatibility

Grin Technologies Ltd

Vancouver, BC, Canada

ph: (604) 569-0902

email: info@ebikes.ca

web: www.ebikes.ca

Copyright © 2023

1 Introduction

Thank you for the purchase of Grin Technologies Torque Arm V7! This device helps positively lock M12 axles on regen capable hub motors against the back and forth rotation caused from alternating forward and reverse torques.

1.1 Features

- Solid machined clamping block of hardened 17-4 stainless steel
- Graded bolts apply over 2000 pounds of clamping force
- 11mm thickness ensures maximum engagement with axle flats
- Splined arm interface for easy for orientation
- Versatile design works with both front and rear motors
- Deep 'J' curve avoids interference with fender and rack eyelets
- All stainless steel for excellent corrosion resistance
- Designed, tested, and manufactured in Canada

1.2 Parts

The following hardware is included in your kit.

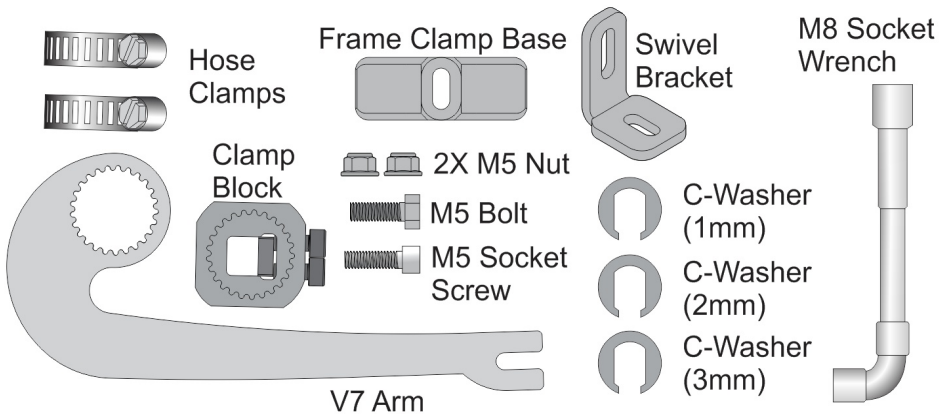

Figure 1: Parts included in V7 torque arm package.

2 Principles of Operation

All hub motors generate a strong reaction torque on the motor axle which must be restrained for the axle not to spin. In hub motors capable of regenerative braking, this torque reversed direction between braking and accelerating. Conventional torque arms can prevent the axle from exerting a huge spreading force on the dropouts, but they do not stop the small amount of rotation that takes place as the torque alternates clockwise and counter clockwise.

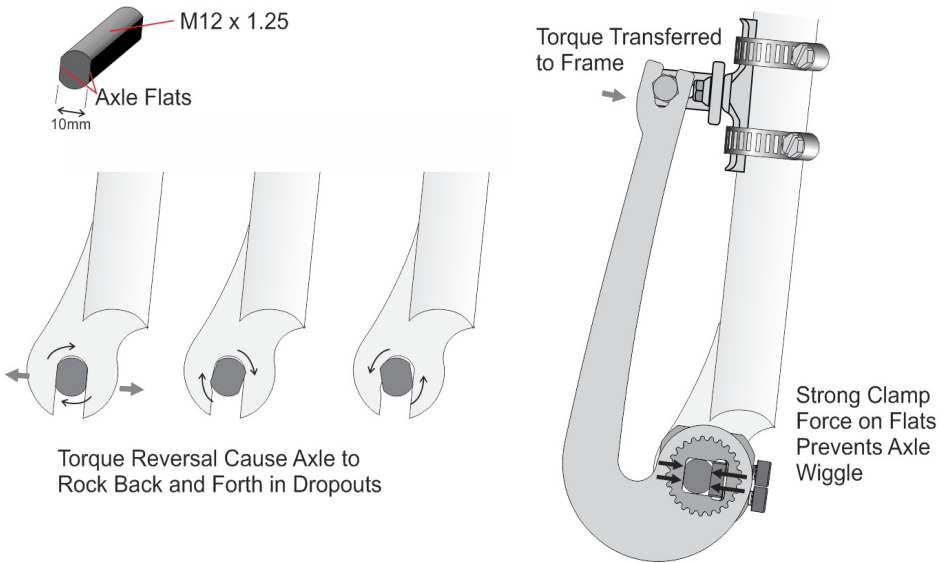

Figure 2: Illustration of axle wiggle in regen system.

Even if a torque arm appears tight initially, the extreme forces will always deform the metal on the axle flats such that some rotation will develop regardless. Eventually this back and forth play will get more serious and result in axle nuts coming completely loose.

The Torque Arm V7 solves this issue by putting an enormous preload clamping force on the axle flats. A sliding block of 17-4 hardened stainless steel compresses the axle from the tightening of two screws so that high axle torques do not result in any noticeable rotation. Furthermore, the axle is fully captive so that even if the screws loosen or strip their threads, the axle will still be contained.

3 Installation

Please read these installation steps before attempting to install the arm to save yourself potential grief.

3.1 Determine Install Position

There are several potential orientations for our Torque Arm V7. It can fit on either the left or right side, and either in front of or behind your tubing, and the clamping block can be under or on top of the arm.

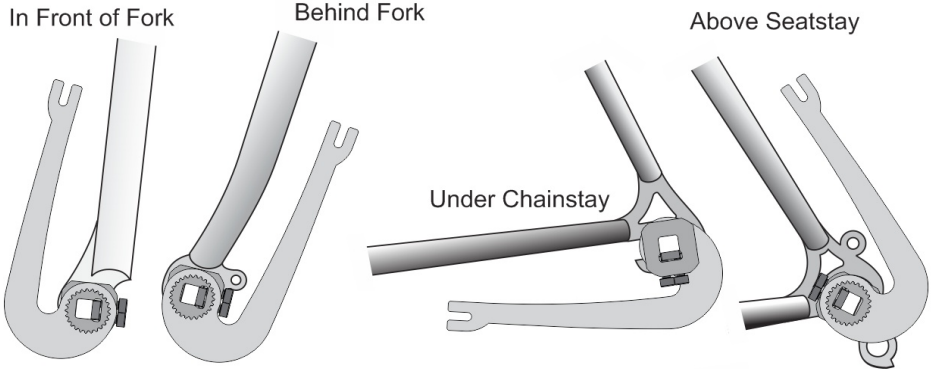

Figure 3: Examples of possible positions. Clamp block can be on either side of arm.

The position of disk brake calipers, fender and rack hardware, length of axle threads, or other interfering geometry may dictate a certain placement. If possible, the torque arm should also be on the opposite side of the motor cable exit. The axle is strongest on the side without a cable channel.

3.2 Assemble Frame Clamp

Prepare the frame clamp by mounting the swivel bracket onto the clamp base, using the M5 bolt and flanged nut. Loosely attach this to your bicycle frame tubing with the two hose clamps. The 8mm socket wrench conveniently fits both fasteners.

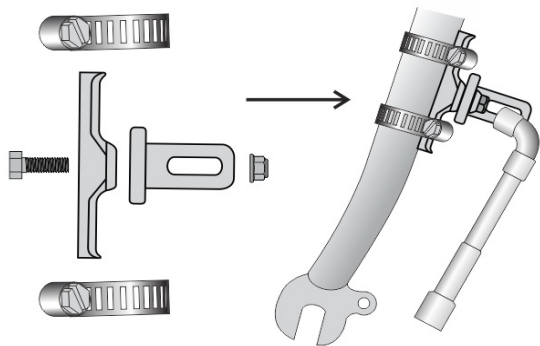

Figure 4: Frame clamp in place, but not tight.

3.3 Determine Arm Angle

Slide the clamping block loosely over the motor axle and place the V7 arm on the block to determine which spline position aligns with the frame clamp. Note the angular position of the insert in the splines. If the best fit appears in between two spline locations, you may rotate the clamp block 180 degrees to achieve a half spline rotation. There are markings to facilitate noting and recalling this position.

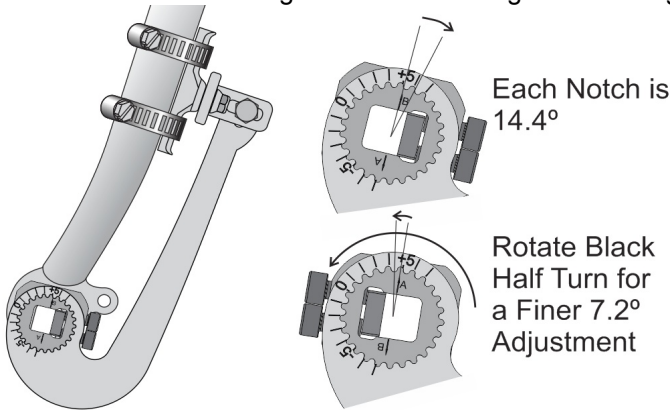

Figure 5: Orient block and arm on axle flats and find position where the arm intersects frame clamp. Laser markings help facilitate and recall alignment.

3.4 Set Arm onto Clamp Block

The fit between the clamping block splines and the arm piece is intentionally quite snug. Remove the arm and block from the bike and use either a hammer or a vise to fully set the the splines into each other at the noted angular position.

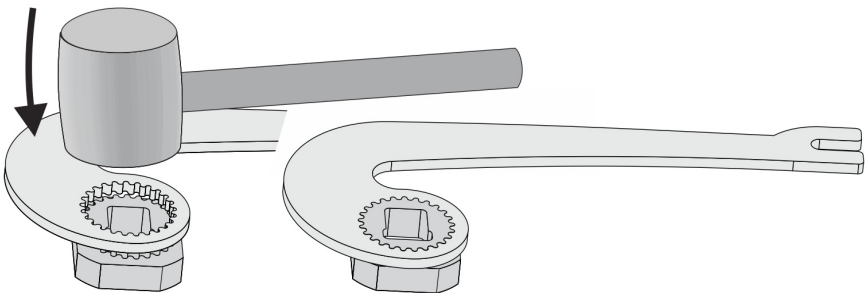

Figure 6: Pound press arm onto block until flush, using hammer or vise.

The tight fit ensures that both pieces act as one, conveniently staying together in the right position if the torque arm needs to be removed and reinstalled.

3.5 Reinstall Hardware

If the dropout slot has lawyer lips, slide the minimum number of 'C' washer(s) as a spacer directly over the dropouts. This ensures that the wider torque arm piece clears the protruding lip and sits flat. The kit includes 1, 2, and 3mm thick washers to permit spacing up to 6mm total. Use the least spacing required for the clamping block to sit flat.

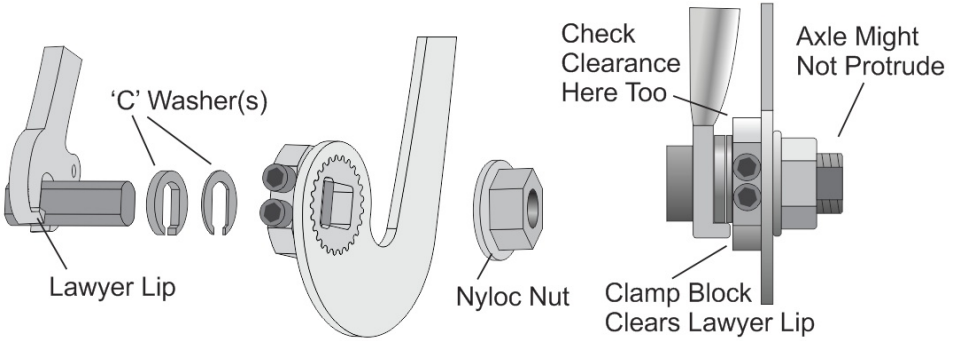

Figure 7: Hardware order. Various thickness 'C' washers help clamp block clear lawyer lips and fork blade, but excessive spacing may not leave much axle thread for the nut. Threadlocking compound should be applied if the the axle does not reach the end of the nyloc.

Slide the assembled torque arm onto the axle and hold it in place with the M12 Nyloc nut. Attach the torque arm to the frame clamp using the M5 socket screw and nut, and tighten the fasteners in the following sequence:

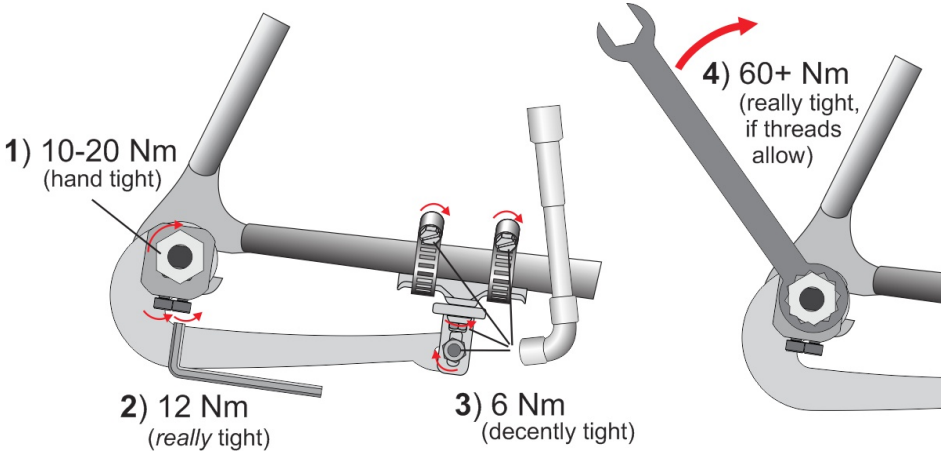

Figure 8: First seat the axle snug in the dropouts with 10-20 Nm on the axle nut. Next tighten clamp block screws to 12 Nm with a 4mm Allen key to fully lock the axle. Then tighten the frame clamp hardware, and finally go back to tighten the axle nuts all the way, at least 60 Nm.

4 Additional Notes

4.1 Periodic Checks

Even with the arm in place we still recommend periodically checking the state of the axle nuts, the two M5 clamping screws, and all fasteners in the frame clamp assembly to ensure that they are really tight. If you find that either of these critical fasteners is regularly getting loose over time, it is a sign that they were not initially set tight enough.

4.2 Heatshrink Tubing

Two lengths of black silicone tubing are supplied with the kit and can be cut to length and slide over the bands of the hose clamp. This both protects the paint on the bicycle tubing and makes the hose clamp itself more discrete. Its use is entirely optional.

4.3 Which Side?

In motors where the cable passes through a hollow center in the middle of the axle, it is always preferable to mount the torque arm on the *opposite side* of the wire exit where the axle is solid. Hollow axles have less than half the strength of solid axles for transmitting torque and are more likely to deform or break.

There are some cases where this is not possible due to interference with derailleurs or disk brake calipers, and the torque arm will have to be installed on the same side as the cable exit. In such situations, be extra sure that the axle nuts are on tight so that an appreciable share of the torque transmission is achieved through friction on the dropout face.

4.4 Insufficient Axle Length

The clamping block in the Torque Arm V7 is 11mm thick. This ensures that the clamping force is spread over a sufficiently wide area of the axle flats, but it also reduces the amount of threads available for the axle nut. As long as the nut has three full turns of good thread it will hold adequately. However, in this case, you will need to use threadlocker compound (such as Loctite 243) to prevent the nut from loosening as the axle will not engage with the nylon retainer in the nyloc nut.

4.5 Aluminum Dropouts

There is no issue using the hub motor on a bike frame with aluminum dropouts with a properly installed Torque Arm V7. The arm eliminates most of the forces that damage softer aluminum and negates the concern that aluminum forks are not strong enough.

4.6 Suspension Forks

Similarly, there is no intrinsic problem using a hub motor with a torque arm on front suspension forks. The main reason people advise against using hub motors on suspension forks is because most suspension forks are aluminum, and aluminum forks *without* torque arms are prone to spreading or breaking. With a torque arm this issue is eliminated.

That said, many models of suspension fork are cast with a deep recess for the axle nut, and often this recess is too small in diameter to accommodate the arm.

4.7 Torque Arm Removal

The torque arm can be removed and reinstalled numerous times whenever the wheel needs to be removed from the bike. Just be sure to put things back in the same sequence and to the same recommended fastener torques.

It is also possible to part the clamping block from the arm and reinstall it at a different angle when migrating between bicycles. Simply use a hammer to separate the two pieces and press them back in the new position.

5 Limitations

The Torque Arm V7 greatly increases the safety and security of a regen capable hub motor installation, but motors with strong regen are tricky. This is especially true with 12mm axles as those do not have much contact flat to pinch against rotation.

Grin has extensively tested various motor axles with this torque arm to failure, and in all cases it has been the axle that shears in two before it can spin out inside the clamping block. With a hollow axle the shearing can happen at under 80 Nm, while solid axles usually fail between 150-200Nm. The cyclic back and forth nature of regen can cause fatigue weakening over time resulting in failures at lower torque levels.

For best results, always make sure that the axle nuts are well tightened as this ensures that the reaction torque is further shared between the torque arm and friction of nuts with the dropout face.

We recommend limiting the maximum motor torque to 50 Nm in these installations to have some margin of safety.

Feel free to contact us at info@ebikes.ca for additional support.