

The Main9 Superharness

User Manual – Rev0

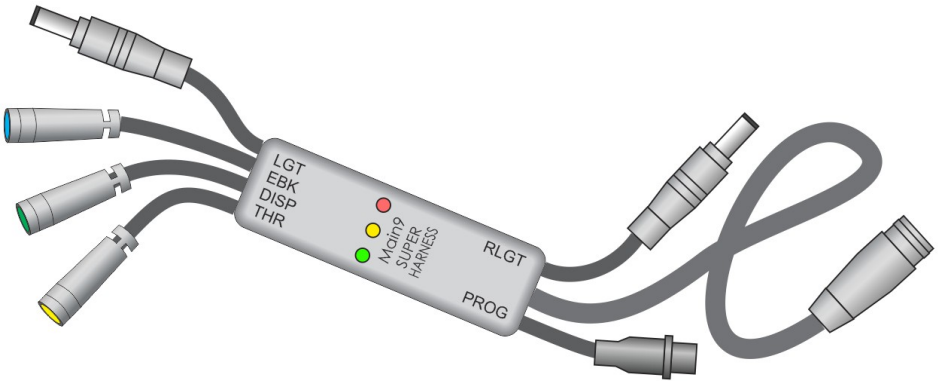

Grin Technologies Ltd.
Vancouver, BC, Canada

ph: (604) 569-0902
email: info@ebikes.ca
web: www.ebikes.ca

Copyright © 2024

1 Introduction	1
2 Connectors	2
2.1 Front Signal Plugs.....	2
2.2 DC Light Plugs.....	3
2.3 Mains Signals Plug.....	3
2.4 Programming Port.....	3
3 Control Functionality	4
3.1 Standard Throttle.....	4
3.2 Bidirectional Throttle	5
3.3 Digital Ebrake Control.....	5
3.4 Analog Ebrake Control.....	6
4 Display Options	7
5 DC Light Ports	8
5.1 Front Port.....	8
5.2 Rear Port.....	9
6 Installation	10
7 Setup and Configuration Mode	11
7.1 Entering Setup Mode.....	11
7.2 Configuring Front Light Port.....	11
7.3 Configuring Rear Light Port.....	11
7.4 Configuring Digital Ebrake Behavior.....	12
8 Additional Details	12
8.1 Minimum Throttle Current.....	12
8.2 Running Without a Throttle.....	13
8.3 Regen with Dual Throttles.....	13
8.4 Multiple Regen Modes.....	13
8.5 LED Fault Codes.....	14
9 Specifications	15
9.1 Electrical.....	15
9.2 Mechanical.....	15

1 Introduction

Most generic ebike systems have some variation of a main cable harness. This connects to a multi-pin plug on the motor controller on one end, and at the other end splits out into separate throttle, ebrake, display and light ports near the handlebars.

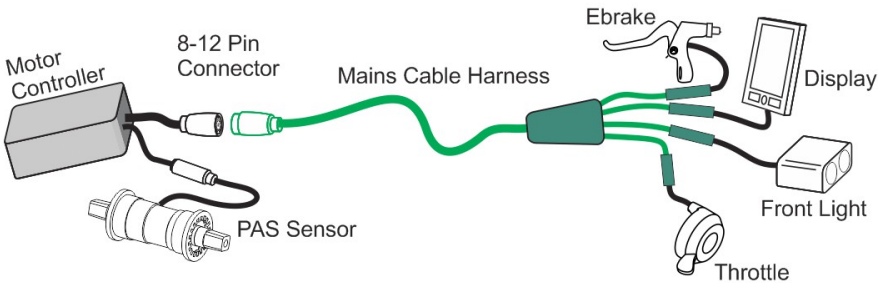

Figure 1: Example of a Mains Harness (Green)

Grin's Main9 Superharness is a device that looks similar to this for use with our V6 Phaserunner/Baserunner controllers. Unlike conventional harnesses, it contains an internal circuit board to provide extra functionality.

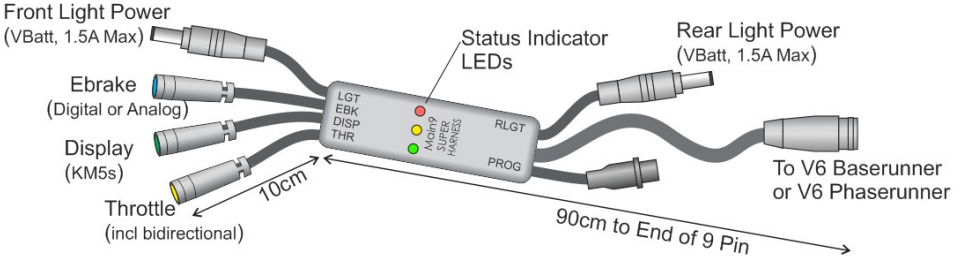

Figure 2: Superharness contains active circuitry

These features include:

- Multiplexing various possible brake signals (digital, analog, bidirectional throttle) into a unified regen command to the motor controller.
- Enabling high wattage front lights to be turned on and off via a display console.
- Enabling a port for the activation of rear brake lights.
- Providing protection against faulty accessories.

2 Connectors

The Superharness uses overmolded Higo equivalent ebike connectors for all signal lines. These plugs are waterproof and reliable when connected, but it is possible to damage the pins by forcing them in the wrong way. Be sure to align the arrows and double check that you are matching the same pin count on the male and female sides.

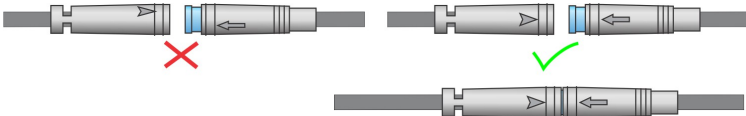

Figure 3: The alignment arrows can be subtle and hard to see. Jamming connector when misaligned can damage pins.

Unlike the JST-SM and other standards, you cannot easily probe the signals for troubleshooting.

2.1 Front Signal Plugs

The front signals are all of the female Higo MiniB standard. Not all cable suppliers use the same colour-to-pin mapping or even the same signal mapping. We have shown some alternate known colour standards in brackets.

<p>(2) Throt Blue [Yellow]</p> <p>(1) Gnd Black</p> <p>(3) 5V Red</p> <p>Throttle Plug (3P Higo MiniB)</p>	<p>The throttle hookup is a conventional 3 pin Higo standard and expects to see a hall-effect throttle with a ~0.9 to 4.2V command signal range.</p>
---	--

<p>(2) Digital Ebrake Yellow</p> <p>(1) Gnd Black</p> <p>(3) Analog Ebrake Blue</p> <p>(4) 5V Red</p> <p>Ebrake Plug (4P Higo MiniB)</p>	<p>The ebrake employs the seldom used 4 pin Higo plug. In addition to 5V and Gnd pins, it has both digital and an analog ebrake inputs for use with both conventional cutoffs and proportional brake levers.</p>
---	--

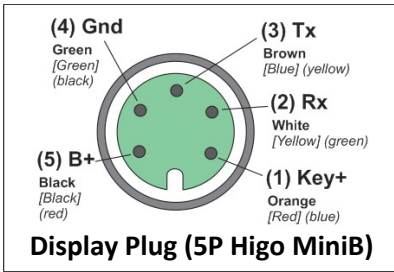

The display plug uses a 5 pin Higo connection* wired in one of the more common of several known pinout standards.

***Note, some displays are using the same 5 pin connector but with different choice of the pin assignments. A wrong pinout can easily fry things. Observe that Batt+ is black.**



2.2 DC Light Plugs

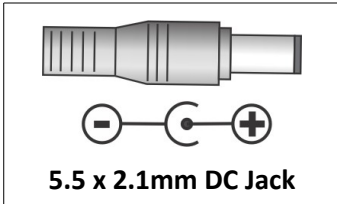

The front and rear power ports use 5.5 x 2.1mm DC jacks and present full battery voltage on the pins when enabled.

These use low side MOSFET switches, VBatt remains connected when the power port is off.

2.3 Mains Signals Plug

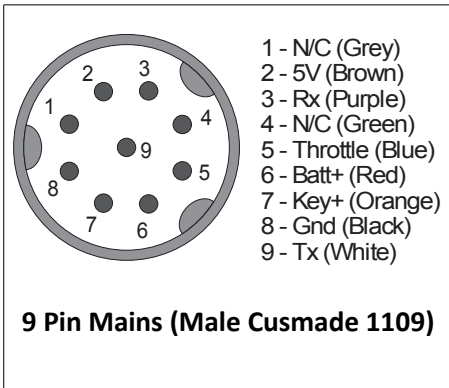

The 9 pin main hookup to the Phaserunner or Baserunner controller uses a male Cusmade 1109 connector. The Tx and Rx lines pass through to the display.

The controller turns on when Key+ is shorted to Batt+ via the display. Note that the throttle output of the Superharness goes to the blue wire (called Analog Input 2/Brake1) of the controller.

2.4 Programming Port

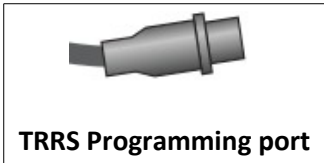

Finally a TRRS jack is used for firmware programming and debugging purposes during development. This is a factory connection only.

3 Control Functionality

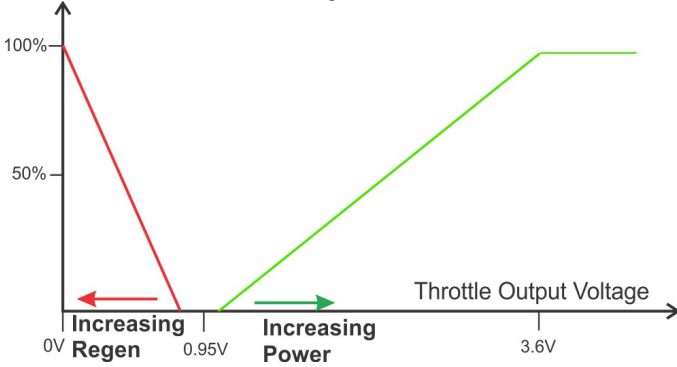

Figure 4: Single throttle output voltage of Superharness controls both power and regenerative braking in Phaserunner/Baserunner controllers.

The Superharness is able to combine the signals coming in from throttle and ebrake devices into a single voltage output to the motor controller. That output signal floats at 0.95V, increasing to 3.6V for maximum power, and decreasing to 0.0V for maximum regenerative braking.

3.1 Standard Throttle

A standard hall-effect ebike throttle plugs into the 3 pin yellow Higo connector. This signal is expected to sit at around 0.9V with throttle off and increase to 4.1-4.2V at full throttle engagement.

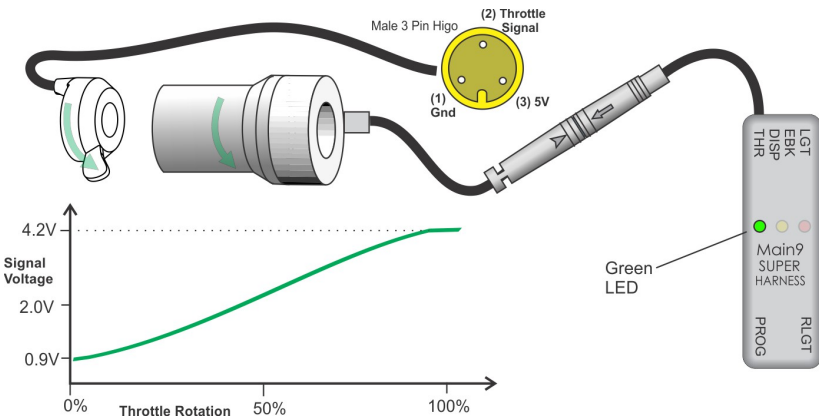

Figure 5: Signal output of a typical throttle. Green LED increases in brightness with throttle position. Pinout shows male throttle side Higo connector.

When the throttle is activated, the green LED will change in brightness from a low dim colour to full intensity allowing you to verify correct throttle operation.

3.2 Bidirectional Throttle

The bidirectional throttles (sometimes called wig-wag throttles) also plug into the yellow 3pin Higo plug. These throttles supplied by Grin sit at 0.9V by default, increasing to 4.1V in the forwards direction and dropping down to 0.0V in the regen direction.

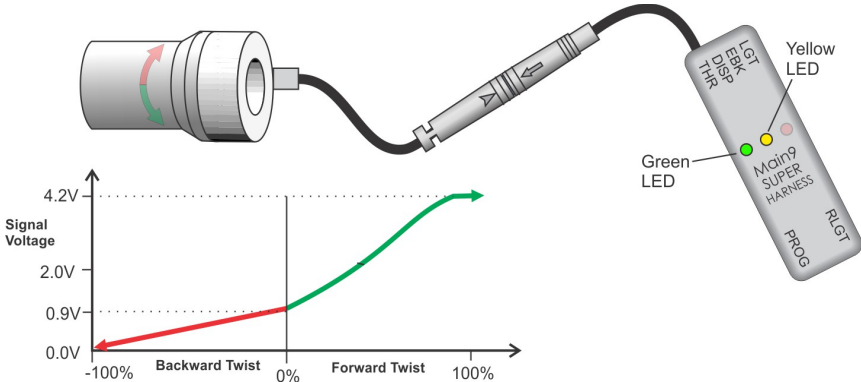

Figure 6: Bidirectional throttles have mid point, allowing both forward and backward twisting. In neutral position signal should sit at ~0.9V. Two-way throttles with 2.5V midpoint are not compatible.

With forwards motion the green LED will increase in brightness just like a standard throttle. In the regen direction, the yellow LED will glow as well.

***Note:** Other vendors of bidirectional throttles will often sit at 2.5V at rest instead of 0.9V. These throttles naturally will not work as their resting voltage is indistinguishable from a valid throttle. Contact Grin about potential modification options for compatibility.

3.3 Digital Ebrake Control

Almost all ebrake sensors currently on the market are digital, either with a magnet and reed switch, a mechanical limit switch, or a powered hall sensor switch. The digital ebrake is activated by shorting pins 1 (Digital Signal - Yellow) and 2 (Gnd - Black) of the 4 pin ebrake plug.

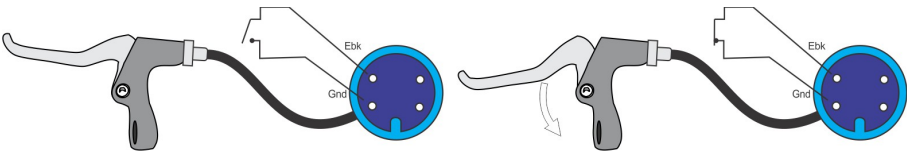

Figure 7: Most Ebrakes are switches that connect the ebrake signal line to ground when the brake lever is pressed. Pinout shown is from male connector perspective.

The red LED will illuminate at full brightness whenever the digital ebrake is pressed, and the output behaviour can be customized (see section 7.4). By default it is shipped so that when the ebrake is active, the superharness outputs 0.6V to the motor controller, equivalent to 25% regen. If the throttle is engaged at the same time, green LED will light up with increasing intensity and the output signal will decrease all the way to 0.0V to provide maximum regen.

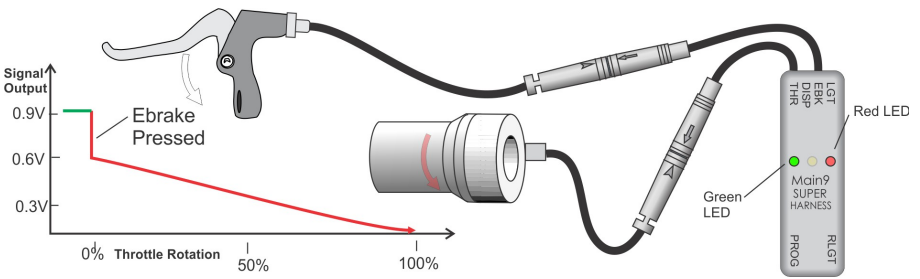
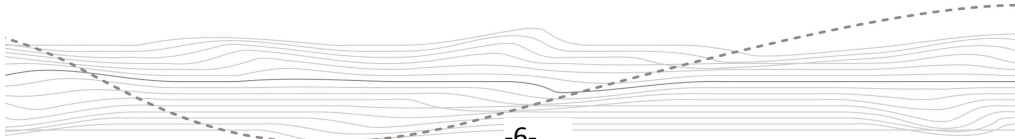

Figure 8: When throttle is engaged at the same time as digital brake cutoff, it controls the regen intensity by modulating output down to 0.0V

3.4 Analog Ebrake Control

The analog ebrake is also hooked up to the 4 pin Higo plug but uses the pin 3 (blue) to provide a ~1V - 4V proportional braking signal. When the analog brake is engaged, the red LED will light up and increase in brightness as the lever is depressed.

As the brake signal increases from 1V to 4V, the throttle output to the controller decreases in proportion from 0.8V down to 0.0V, providing 0 to 100% regen control from initial movement of the brake lever. Continued application of the brake lever will engage the mechanical brakes while regen remains at 100%.



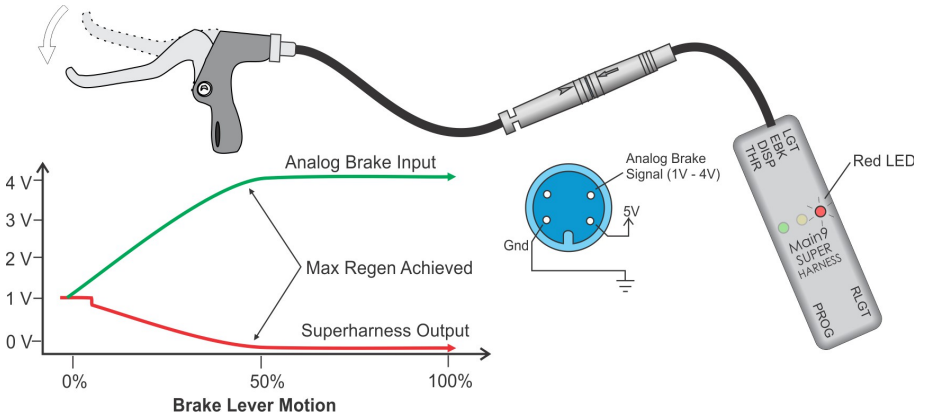

Figure 9: The analog brake lever has the same 1V - 4V nominal output as a throttle. The Superharness remaps this into a 0.8V - 0.0V regen command.

We recommend having just one analog brake lever hooked up to the harness. That way it is possible to employ the mechanical brakes without any regen as well by using the other lever.

4 Display Options

An ebike display is required on the 5 pin plug both to turn the system on and off, and to regulate the assist level from the motor. Grin offers several vetted display models to choose from of different sizes and form factors.

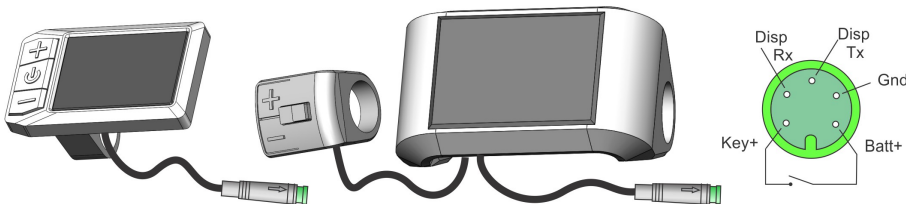

Figure 10: Small displays are available with integrated buttons (left), while larger central displays have separate handlebar switch. Male side display pinout shown. System only powers on when Key+ is switched to Batt+.

These displays all operate on the KM5s protocol and the Superharness monitors the controller to display communication.

KM5s is one of several limited function UART protocols that has spread in the world of generic Chinese ebike systems, and a number of potential displays can work in some capacity. However there is no simple way to

know what communication protocol is programmed on a given device and Grin cannot offer *any* assistance for hooking up and troubleshooting other displays beyond what is documented in this manual.

Our system prominently features regenerative braking which results in negative current and negative wattage on the display, and our displays have been customized to handle signed values and show this properly.

5 DC Light Ports

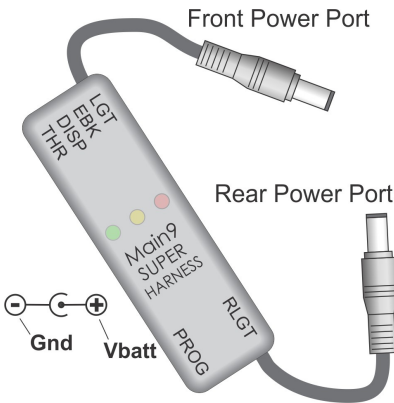

Figure 11: 5.5 x 2.1mm jacks provide convenient access to DC battery power for accessories.

from a DC-DC converter.

The functionality of these DC power jacks can be customized depending on the usage needs.

5.1 Front Port

The front light port is configurable in one of two modes

1. **Always On:** Power to the front light port is activated whenever the Superharness is turned on. This would be the typical mode for running accessories or front lights that have their own on/off switch.
2. **Controlled by Display:** Power to the front light port is activated by the display. The display light function is activated by holding the “up” assist button for several seconds. This mode is ideal for front lights or other accessories that don’t have an on/off switch.

The two 5.5 x 2.1mm DC jacks are primarily intended to power front and rear bike lights, but they can also be used more generally to run other accessories like USB phone chargers, sound systems, handgrip heaters etc.

Each port has self resetting short circuit and overcurrent protections and can handle 1.5 amps - about 50 watts with a 36V battery pack. Internal polyfuses inside the controller will limit the total combined draw.

The devices plugged into this port must be rated to run at the full ebike battery voltage. 12V devices will need to be run

5.2 Rear Port

The rear DC power port can be setup in one of five possible modes depending on the desired behavior

1. **Always On:** Power to the rear light port is activated whenever the Superharness is turned on.
2. **Controlled by Display:** Power to the rear light port is activated by the display's light control.
3. **Brake Light:** Power to the rear light is turned on whenever the rider is actively braking, whether using the digital brake cutoff, the analog brake levers, or bidirectional throttle engagement. This behavior is active regardless of the display's light control. It is ideal for systems running a separate brake light from their regular rear light.
4. **Blinking + Solid Brake Light:** The rear light runs at a 2 Hz blinking mode when the display's light control is on and converts to a steady light whenever the brakes are engaged. This mode allows the same light to serve as both a regular rear indicator light and as a brake light. This mode is best for simple lights without switches and mode control. Not all models of ebike light appreciate being strobed externally.
5. **Solid + Blinking Brake Light:** This final mode is an inversion of #4, namely the rear light will be on steady whenever the display lighting is turned on, and it will switch to a blinking light when braking is engaged.



Figure 12: The rear light port can be used as a brake indicator in modes 3, 4, and 5.

6 Installation

The Superharness is designed to mount beside the stem of the bicycle with the LEDs visible to the user. A tilting mounting bracket is supplied to secure it in place with two cable ties. The 9 pin cable runs backwards on the downtube to the Baserunner or Phaserunners motor controller, while the signal cables face forward in front of the handelbar.

A 1.5m length of spiral wrap and a velcro sleeve is also included to tidy all electrical cables. In most setups, the neatest installation is achieved by having the ebrake and throttle cables follow parallel with the existing shifter or brake housings. The spiral wrap holds these together and eliminates the need for any cable ties.

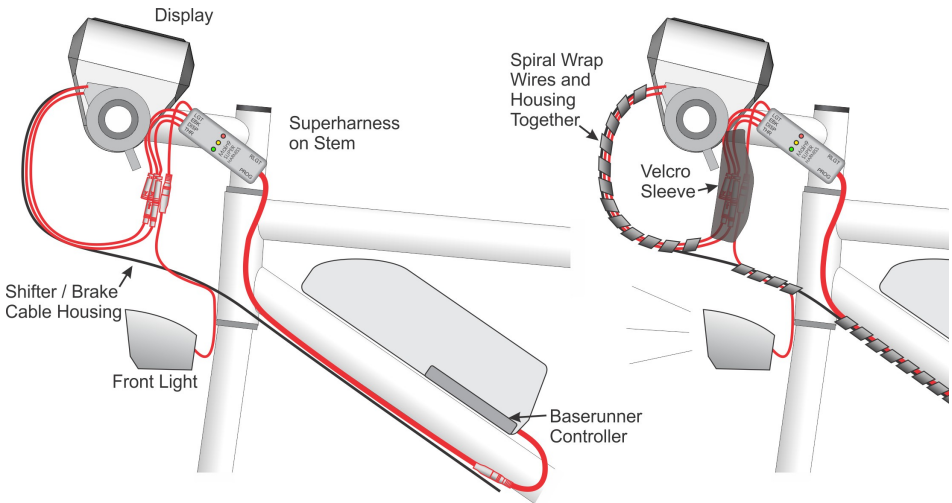

Figure 13: Recommended wire management strategy that eliminates need to bundle excess cable. Wires (shown red) should follow existing shifter/brake cable housings (black). Multiple short pieces of spiral wrap is easier to handle than one long length.

Where the brake/shifter housing approaches the bike frame, the electrical cable can split upwards and connect with the Superharness plug.

This 'S' shaped configuration provides the flexibility for one standard cable length to fit neatly with a range of bike hardware. The velcro sleeve can then be used to wrap around all the connectors, and any excess cable (say for the front lights) can be bundled up inside this sleeve.

7 Setup and Configuration Mode

The behavior of the front light port, rear port and the digital brake input can be customized via a setup process that uses the brake lever as a button.

7.1 Entering Setup Mode

Power on the device while the ebrake lever is depressed to access the setup mode. The yellow LED will blink rapidly to indicate that setup is active.

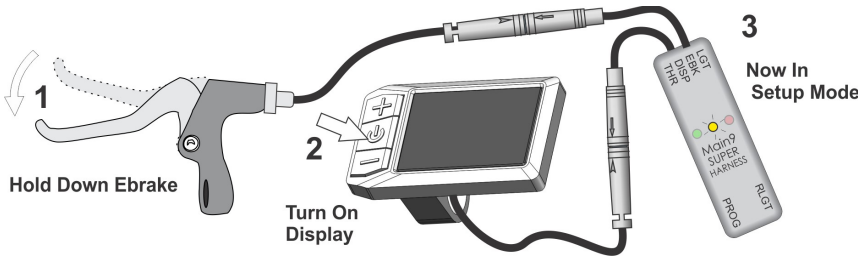
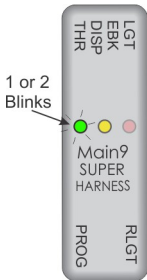

Figure 14: Accessing the setup mode. Yellow LED will strobe.

Note that if at any point the throttle is engaged, the device will exit setup menu and switch to normal operation. That way if the lever is accidentally pressed when the bike was powered up it will still run as expected once the user touches the throttle.

7.2 Configuring Front Light Port



On releasing the lever, the green LED will blink in a flash pattern to indicate the selected control mode:

- 1 Blink = Always On**
- 2 Blinks = Controlled By Display**

Tap the ebrake lever to switch modes. Hold the ebrake lever for 3 seconds to select the current front mode (yellow LED will glow bright once it is saved).

Figure 15: Front Port

7.3 Configuring Rear Light Port

After the front light mode is saved, then the red LED will blink to indicate the rear port control mode:

- 1 Blink = Always On**
- 2 Blinks = Controlled By Display**
- 3 Blinks = Brake Light**
- 4 Blinks = Blinking Rear + Steady Brake Light**
- 5 Blinks = Steady Rear + Blinking Brake Light**

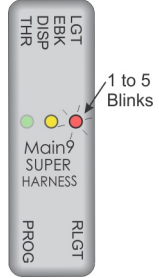

Figure 16: Rear Port Setup

Tap the lever to select the desired behavior, and then press and hold the ebrake lever for 3 seconds to save it.

7.4 Configuring Digital Ebrake Behavior

After the rear light mode is configured in the setup menu, both the red **and** green LEDs will blink together to indicate the selected behavior for the digital brake input.

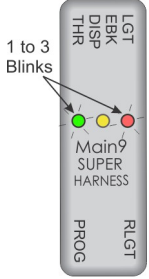

Figure 17: Ebrake Setup

- 1 Blink = Ebrake Cutoff Only, No Regen**
- 2 Blinks = 0.6 V (25%) Baseline Regen, Increases to 100% With Throttle**
- 3 Blinks = 0.4 V (50%) Baseline Regen, Increases to 100% With Throttle**

Pressing the brake lever toggles between the three options and holding the lever for 3 seconds will save it to the device and exit the setup mode.

8 Additional Details

8.1 Minimum Throttle Current

Conventional throttles can have a problematic failure mode if there is a break in the throttle's ground connection. With only 5V and Signal lines connected, the signal voltage will often sit between 3.6-4.2V, indistinguishable from an actual full throttle.

In order to detect this rare fault condition, the Superharness measures the current flowing to the throttle and only responds if at least 2mA is being drawn. If the current is below this threshold and a signal voltage is present it will blink a throttle fault condition (see 8.5).

If the throttle input is controlled with a potentiometer or other voltage source instead of a hall effect throttle, an additional resistor between 5V and Gnd of the throttle plug may be required to draw the necessary current.

8.2 Running Without a Throttle

Grin always recommends having a throttle on the ebike even if the primary control mode is with a PAS or Torque sensor. There is no downside to having a throttle available and it can be an invaluable backup if there are ever problems with the pedal sensor or drivetrain.

That said, the Superharness will function just fine without a throttle attached. The digital ebrake will provide a modest braking force, while the analog ebrake will allow full zero to maximum regen brake control.

8.3 Regen with Dual Throttles

The signal range for the analog brake sensor is identical to a regular hall effect throttle, allowing for interchangeable use of a throttle device instead of a proportional brake lever. A short 4 pin to 3 pin Higo adapter cable can be used for plug and play hookup of a secondary throttle device to control regenerative braking.

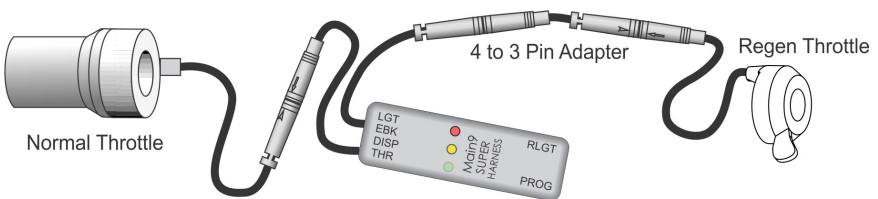

Figure 18: A regular throttle may be used as proportional regen control

This mode is especially useful on systems with hydraulic brakes where there are few options to add a linear sensor to the existing brake lever hardware.

8.4 Multiple Regen Modes

Most users are expected to use just one of the three possible regen control modes based on the hardware that works best for their system; either a digital brake cutoff with throttle modulation, an analog brake sensor, or a bidirectional throttle. But it is possible to have two or even all three of these inputs hooked up at the same time.

If there are multiple regen signals active simultaneously, the Superharness will prioritize the proportional analog brake signal over the other modes.

8.5 LED Fault Codes

The embedded red, yellow and green LEDs do not need to be seen in normal operation but they provide useful feedback about the state of the Superharness and associated peripherals for setup and troubleshooting. These are discussed in section 3 Control Functionality and summarized in the table below

Table 1: LED Control Mode

Yellow LED Pulsing	Standby heartbeat mode. Device is behaving normally without any active signals
Green LED Varying	Throttle is active (>1.1V)
Red LED Varying	Analog ebrake is active (>1.1V)
Red LED On Full	Digital ebrake is active
Red + Green Varying	Digital ebrake active with throttle modulation
Yellow + Green Varying	Bidirectional throttle in regen mode (< 0.8V)

As well, there are a blinking modes to indicate fault conditions. In all blinking fault condition, the throttle output will not exceed 1.0V to prevent driving the motor.

Table 2: LED Fault Flash Codes

Blinking Green	Throttle Fault – Throttle signal was active during power on. Clears automatically when throttle goes low
Blinking Green + Yellow	Throttle Fault – Active throttle signal with insufficient throttle quiescent current.(eg, disconnected throttle Ground)
Blinking Red + Yellow	Low Voltage (<4.5V) on 5V Bus
Blinking Red	Firmware CRC Fault - Contact Grin

9 Specifications

9.1 Electrical

Voltage Range	12V-90V
Front DC Port Over-Current Trip	2.0 A +- 10%
Rear DC Port Over-Current Trip	2.0 A +- 10%
Minimum Throttle Current	2.5 mA
Maximum current from 5V	30mA
Quiescent Current when On	5-8mA plus accessories
Quiescent Current when Off	Depends on display. 0 mA from superharness
Communication Protocol	KM5s

9.2 Mechanical

Dimensions LxWxH	64 x 20 x 11 mm
Weight	74g
Main9 Cable Length	83 cm
Front Higo Cable Lengths	10 cm
Waterproofing	Fully encapsulated electronics. Fine to use in the rain, not for submerged applications.

