

PART NO:
Grin All-Axle V3 Hub Motor

REVISION:
D1

DRAWN: Justin L-E.
DATE: 09-14-2024
www.ebikes.ca
Relevant dimension drawing in mm for external use
Designed, Drawn and Made in Canada

MATERIAL: N/A
WEIGHT: ~4.3kg
SURFACE FINISH: Anodized Alum
SCALE: 1:2

DESCRIPTION:
135mm Nominal Assembly



REFERENCE USE ONLY

THE INFORMATION CONTAINED IN THIS DRAWING IS THE SOLE PROPERTY OF GRIN TECHNOLOGIES. ANY REPRODUCTION IN PART OR AS A WHOLE WITHOUT THE WRITTEN PERMISSION OF GRIN TECHNOLOGIES IS PROHIBITED.

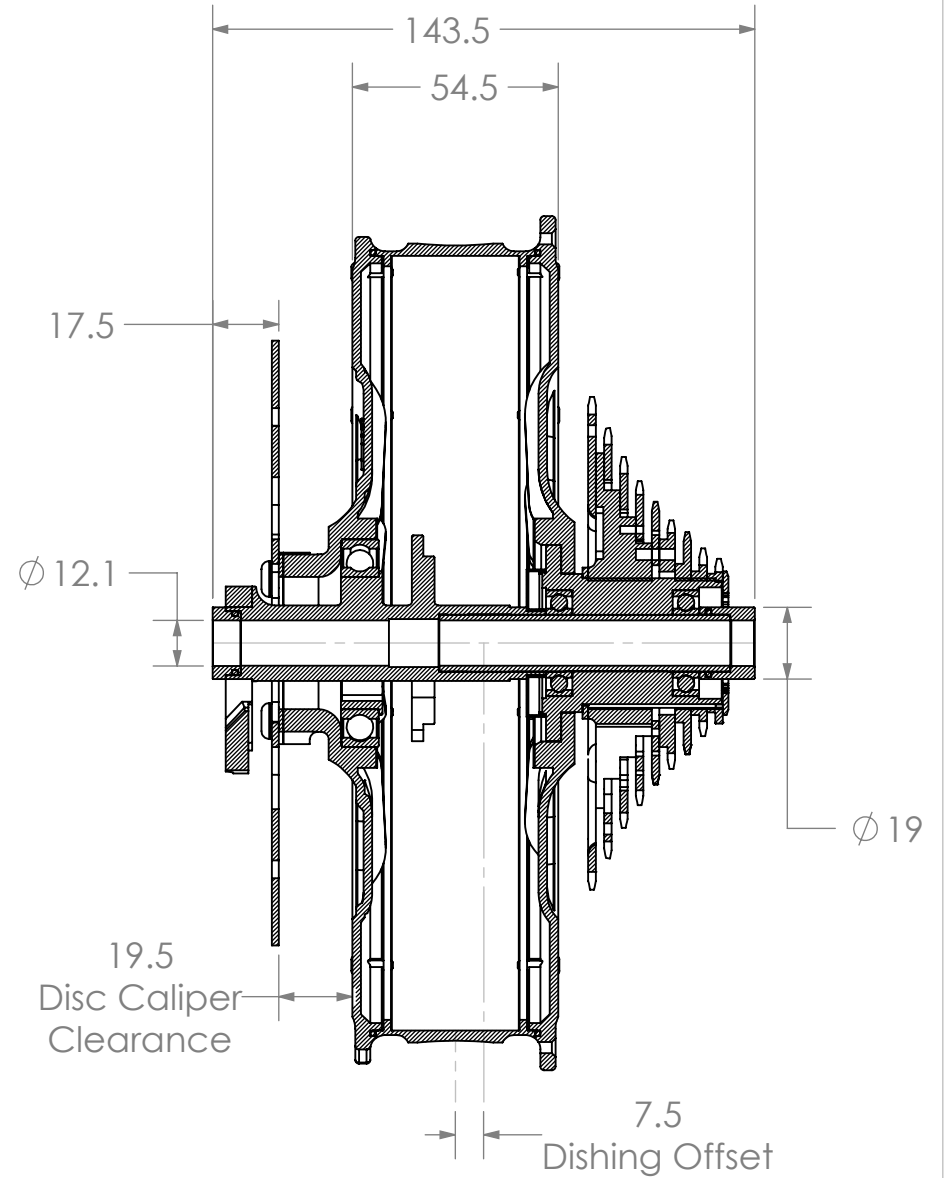
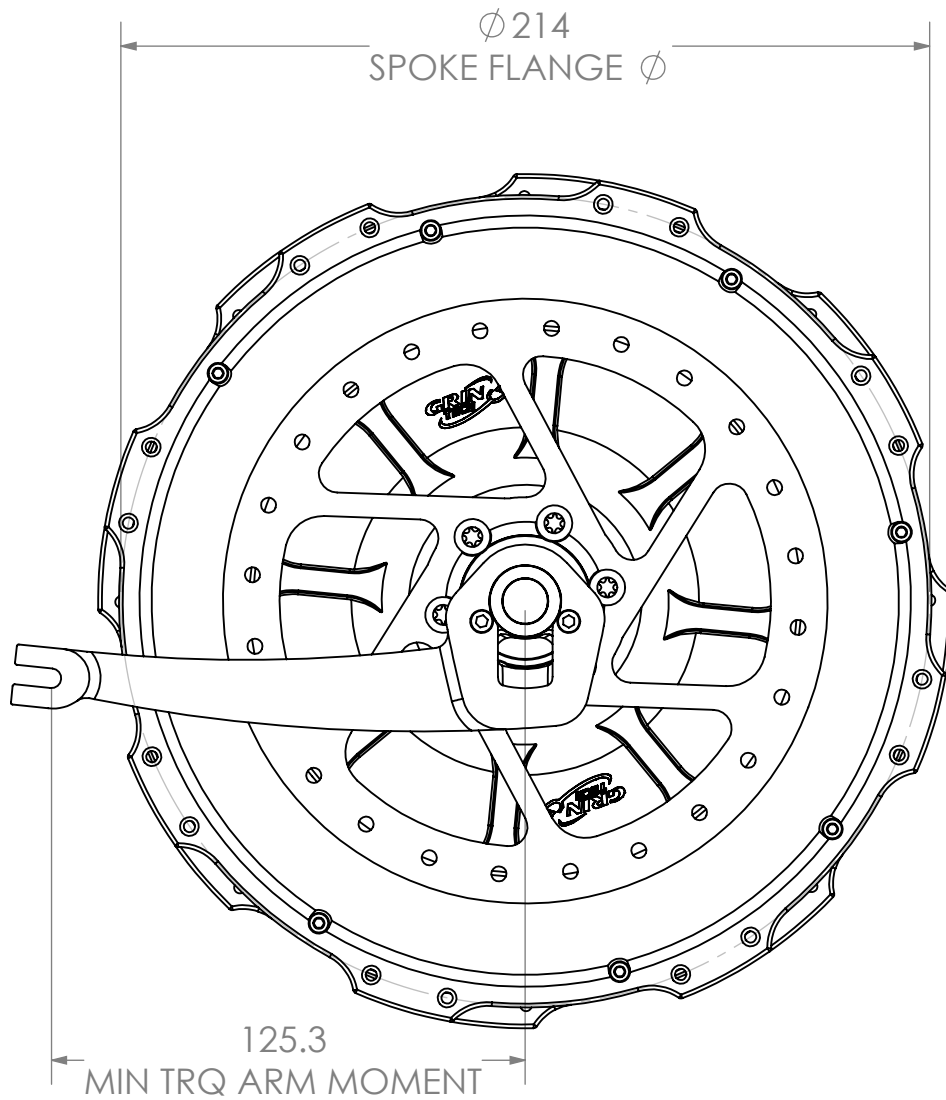

PART NO:
Grin All-Axle V3 Hub Motor

REVISION:
D1

DRAWN: Justin L-E.
 DATE: 09-14-2024
www.ebikes.ca
 Relevant dimension drawing in mm for external use
 Designed, Drawn and Made in Canada

MATERIAL: N/A
 WEIGHT: ~4.3kg
 SURFACE FINISH: Anodized Alum
 SCALE: 1:2

DESCRIPTION:
142mm Thru-Axle Assembly



REFERENCE USE ONLY
 THE INFORMATION CONTAINED IN THIS DRAWING IS THE SOLE PROPERTY OF GRIN TECHNOLOGIES. ANY REPRODUCTION IN PART OR AS A WHOLE WITHOUT THE WRITTEN PERMISSION OF GRIN TECHNOLOGIES IS PROHIBITED.

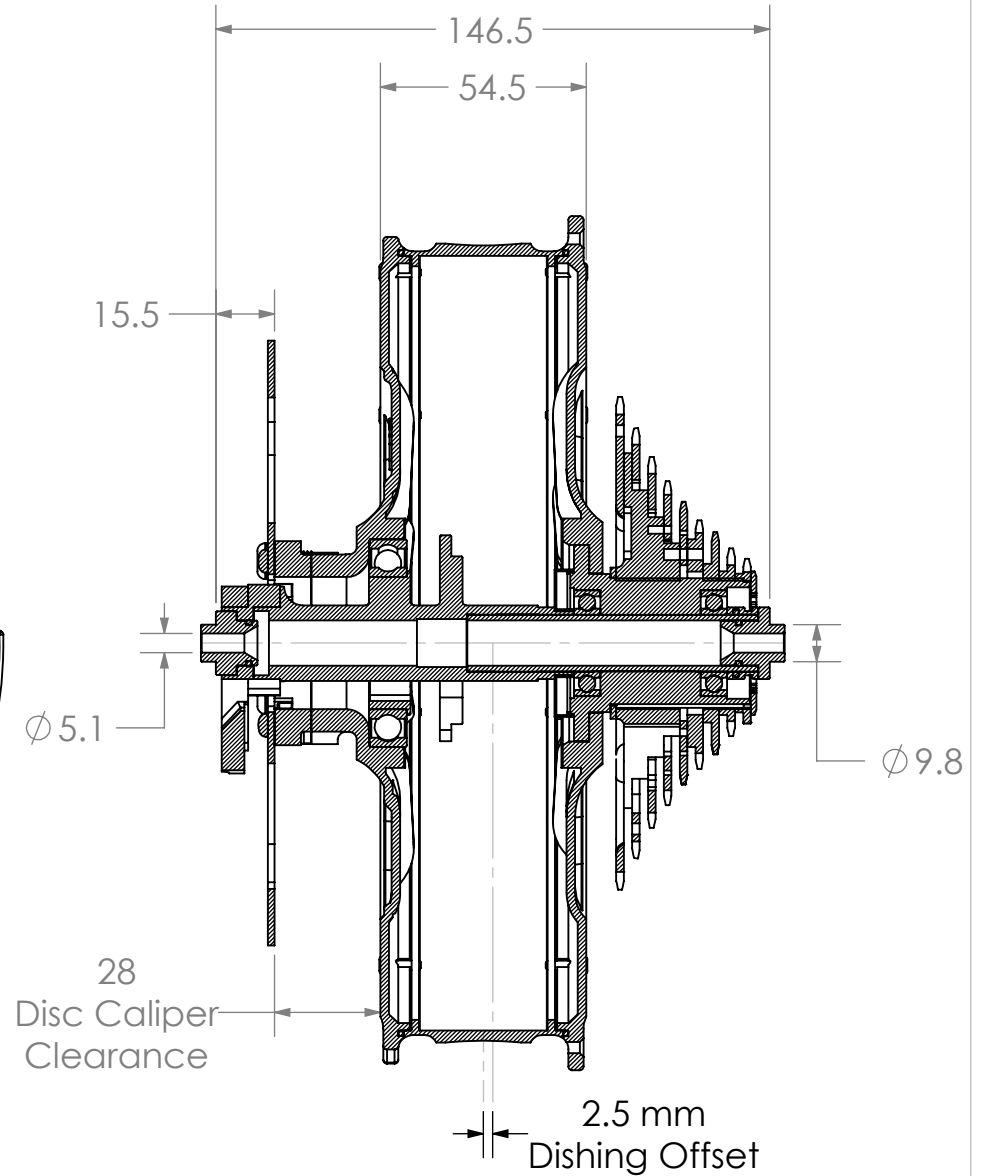
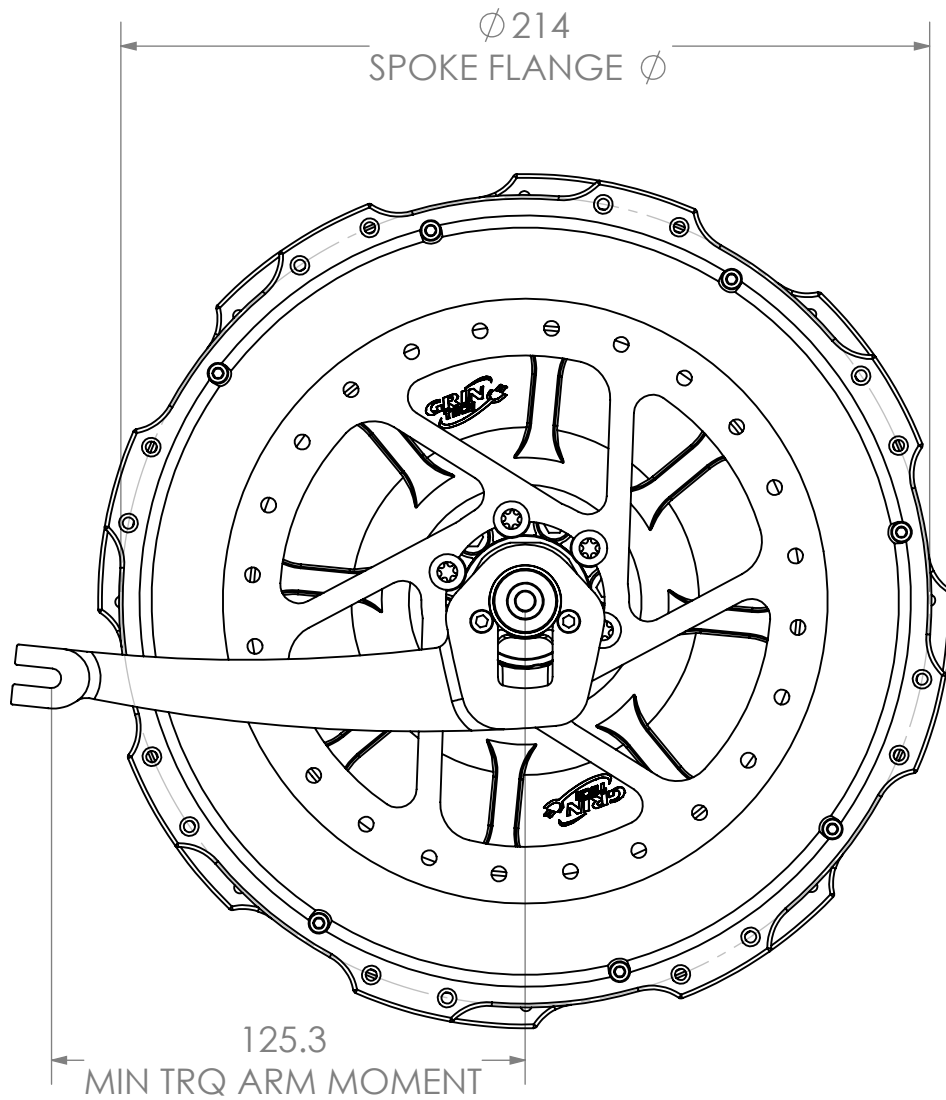

PART NO:
Grin All-Axle V3 Hub Motor

REVISION:
D1

DRAWN: Justin L-E.

MATERIAL: N/A

DATE: 09-14-2024

WEIGHT: ~4.3kg

www.ebikes.ca

SURFACE FINISH: Anodized Alum

Relevant dimension drawing in mm for external use

SCALE: 1:2

Designed, Drawn and Made in Canada

DESCRIPTION:
145mm Tandem Bike Assembly



REFERENCE USE ONLY

THE INFORMATION CONTAINED IN THIS DRAWING IS THE SOLE PROPERTY OF GRIN TECHNOLOGIES. ANY REPRODUCTION IN PART OR AS A WHOLE WITHOUT THE WRITTEN PERMISSION OF GRIN TECHNOLOGIES IS PROHIBITED.

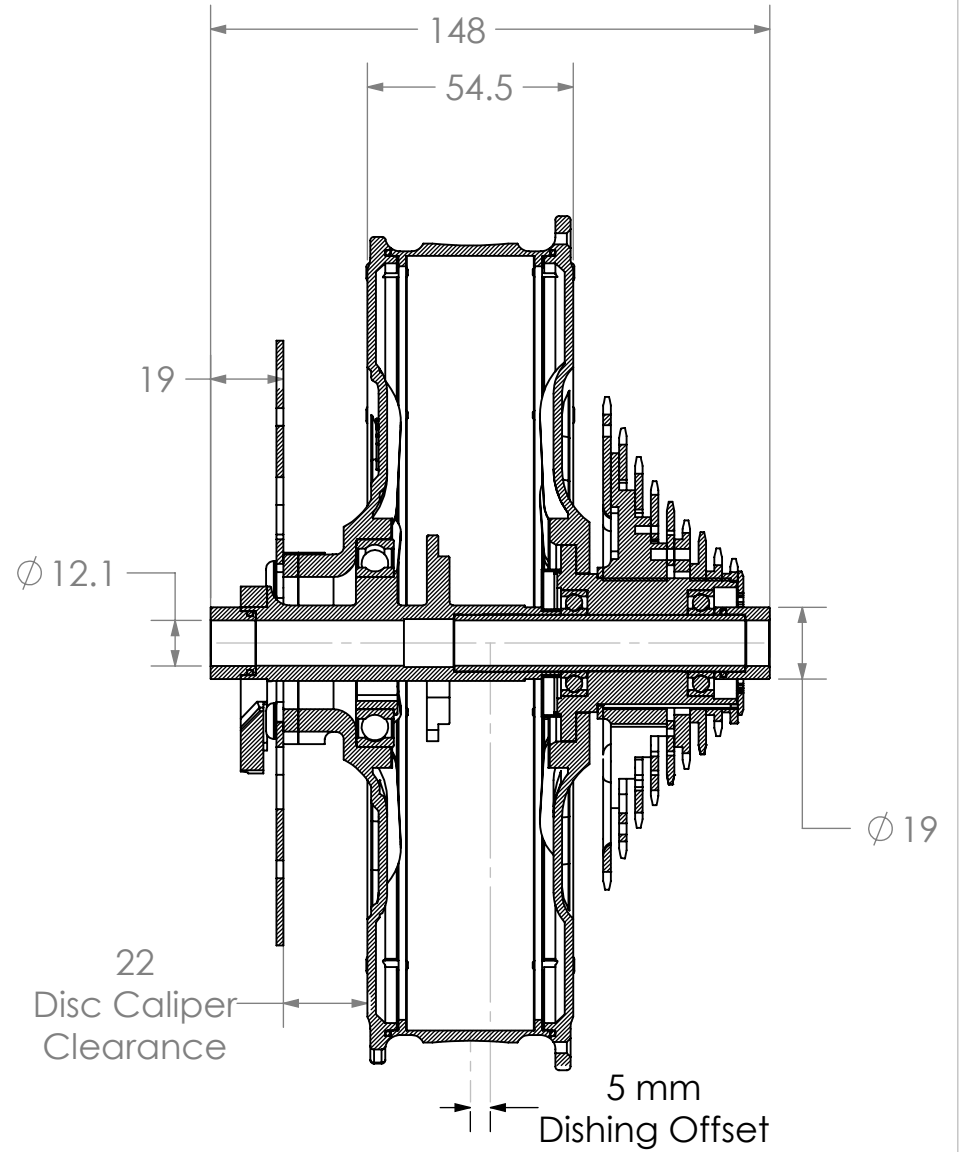
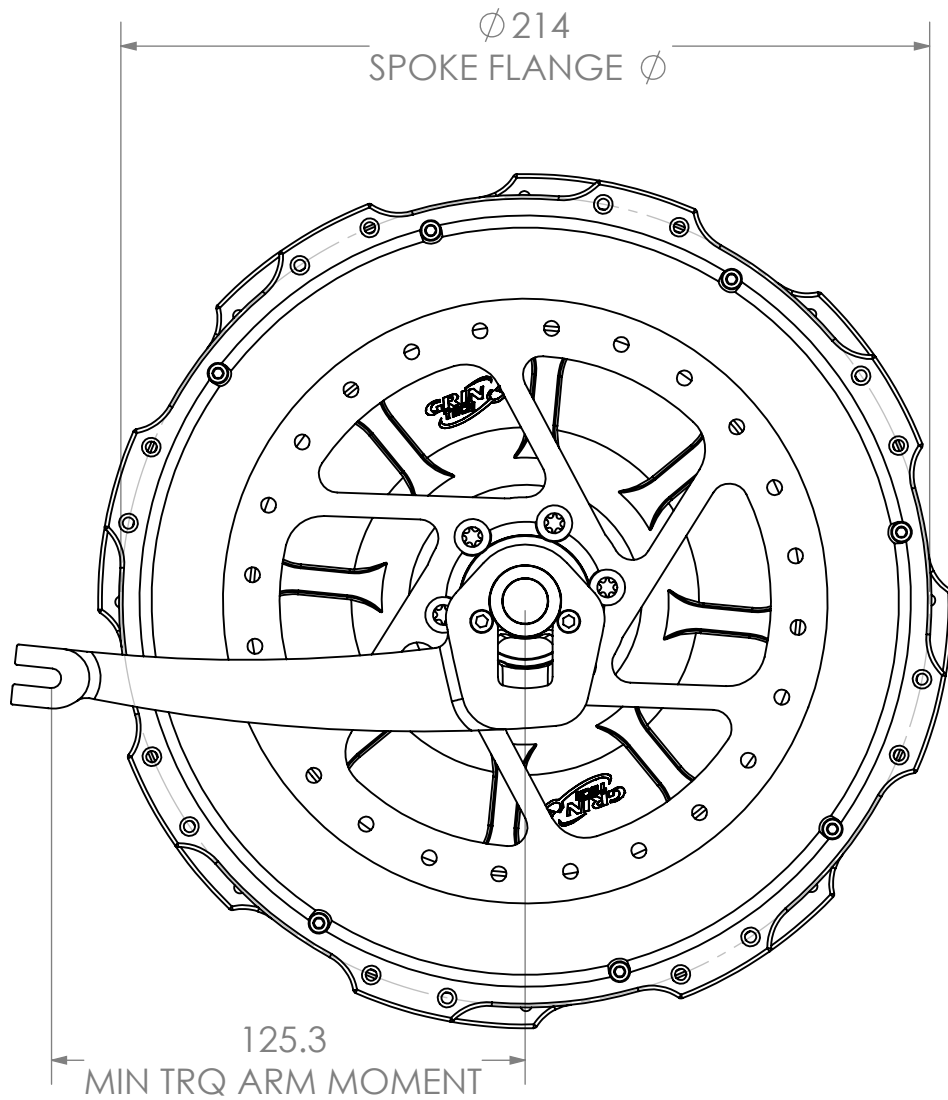

PART NO:
Grin All-Axle V3 Hub Motor

REVISION:
D1

DRAWN: Justin L-E.
 DATE: 09-14-2024
www.ebikes.ca
 Relevant dimension drawing in mm for external use
 Designed, Drawn and Made in Canada

MATERIAL: N/A
 WEIGHT: ~4.3kg
 SURFACE FINISH: Anodized Alum
 SCALE: 1:2

DESCRIPTION:
148mm Thru-Axle Assembly



REFERENCE USE ONLY
 THE INFORMATION CONTAINED IN THIS DRAWING IS THE SOLE PROPERTY OF GRIN TECHNOLOGIES. ANY REPRODUCTION IN PART OR AS A WHOLE WITHOUT THE WRITTEN PERMISSION OF GRIN TECHNOLOGIES IS PROHIBITED.

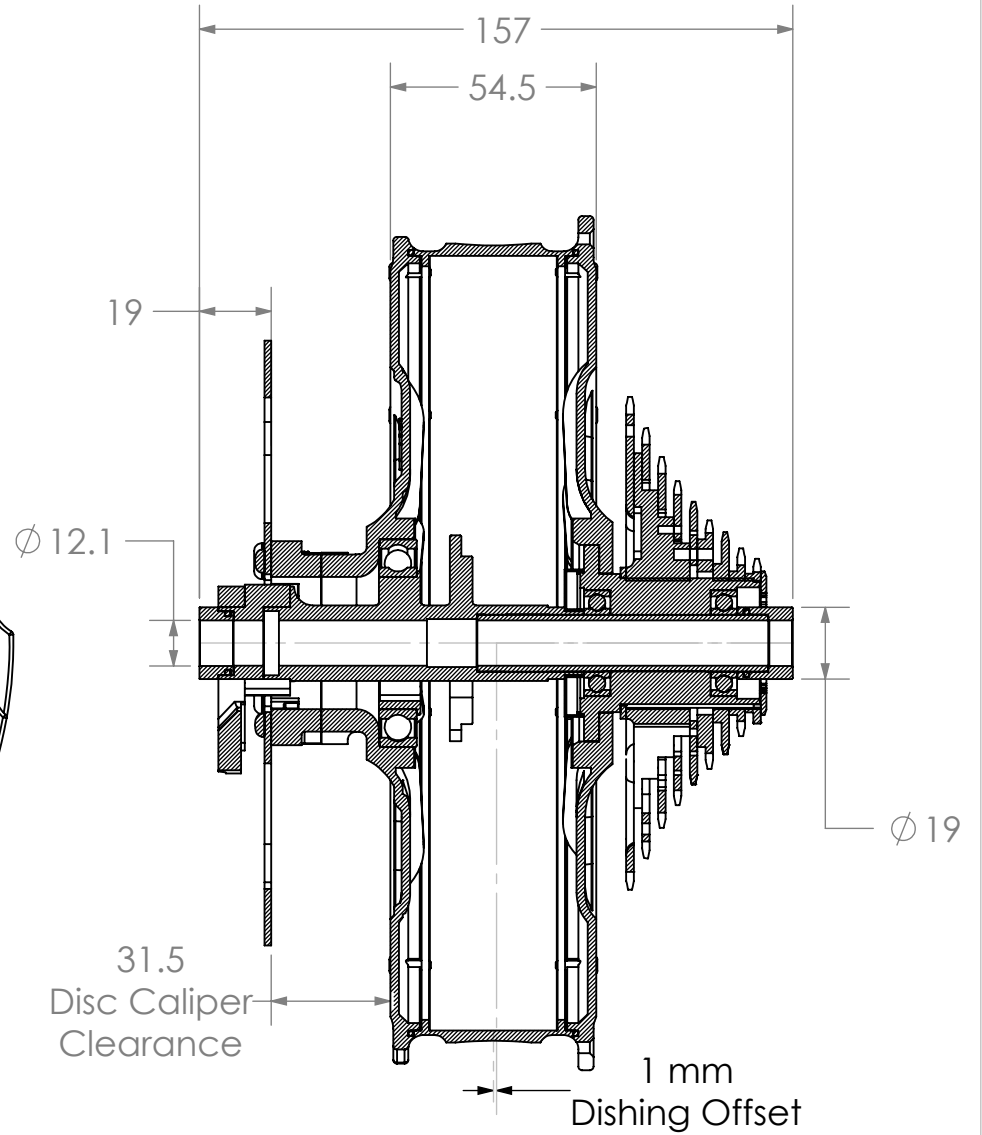
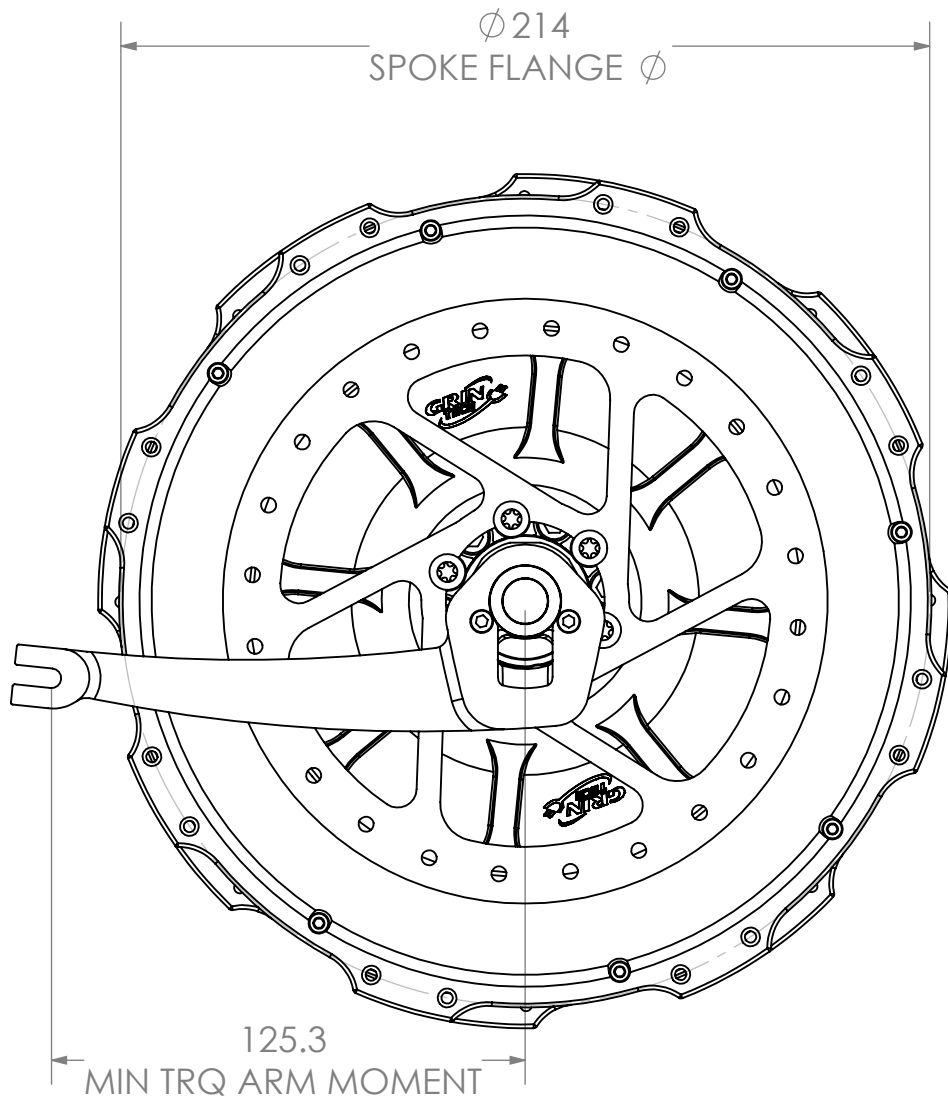

PART NO:
Grin All-Axle V3 Hub Motor

REVISION:
D1

DRAWN: Justin L-E.
 DATE: 09-14-2024
www.ebikes.ca
 Relevant dimension drawing in mm for external use
 Designed, Drawn and Made in Canada

MATERIAL: N/A
 WEIGHT: ~4.3kg
 SURFACE FINISH: Anodized Alum
 SCALE: 1:2

DESCRIPTION:
157mm Thru-Axle Assembly



REFERENCE USE ONLY
 THE INFORMATION CONTAINED IN THIS DRAWING IS THE SOLE PROPERTY OF GRIN TECHNOLOGIES. ANY REPRODUCTION IN PART OR AS A WHOLE WITHOUT THE WRITTEN PERMISSION OF GRIN TECHNOLOGIES IS PROHIBITED.

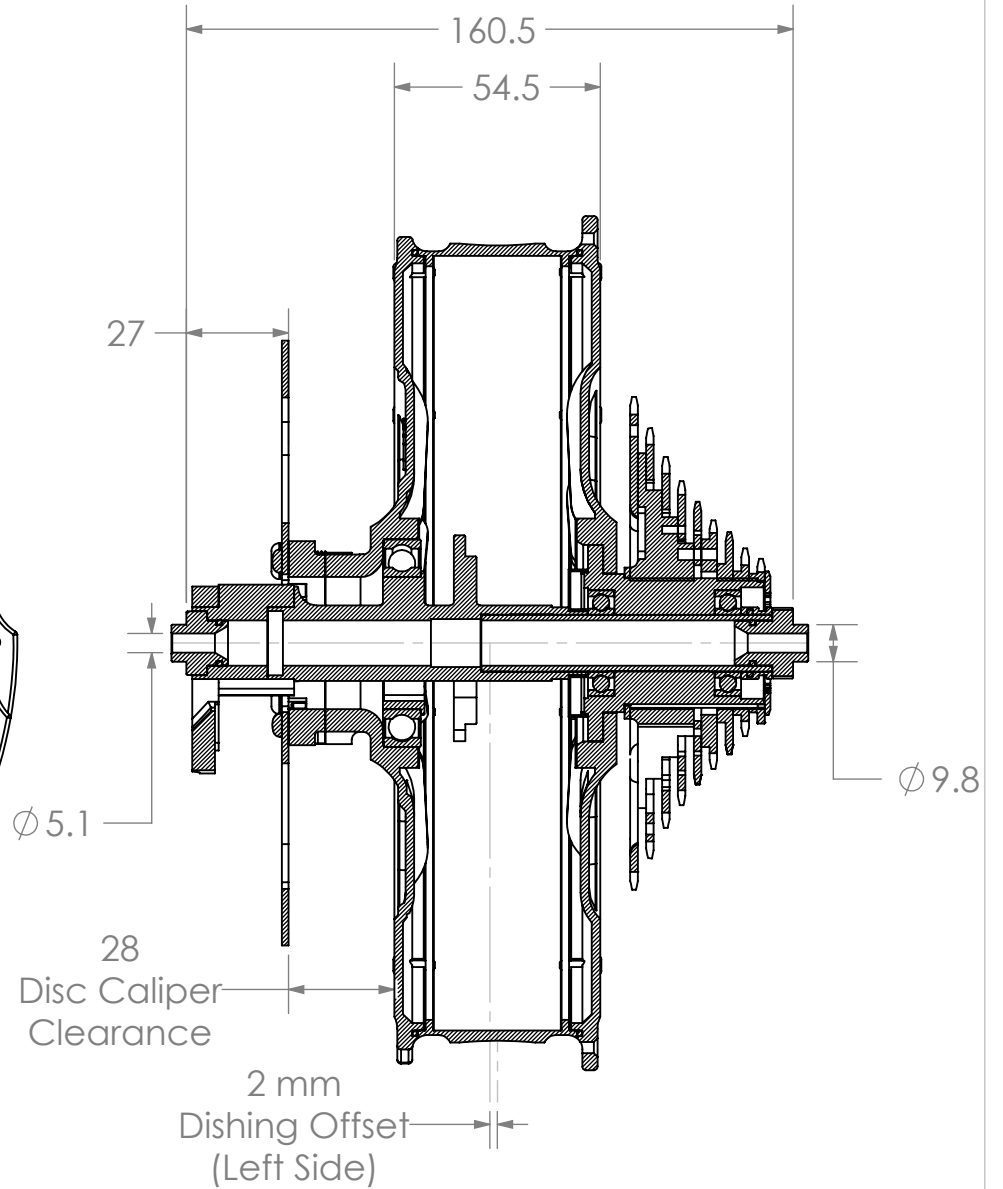
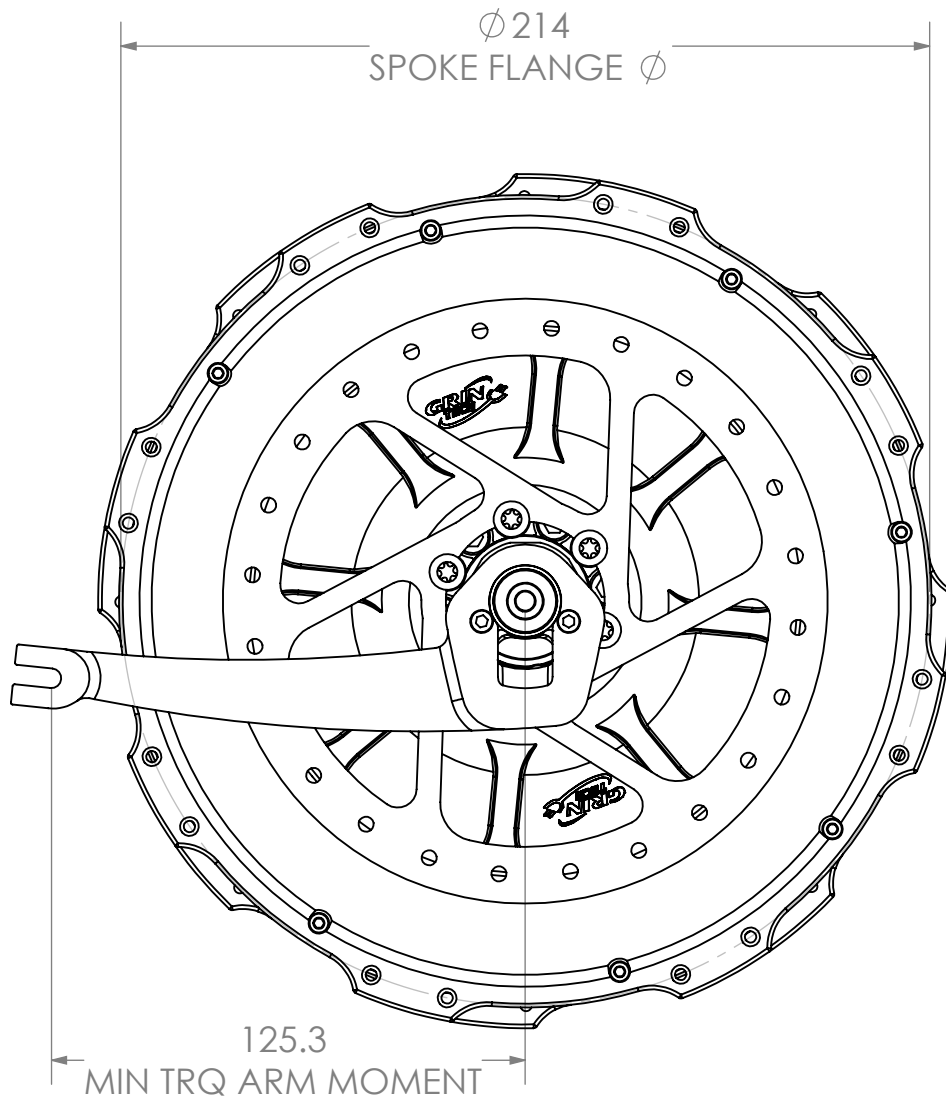

PART NO:
Grin All-Axle V3 Hub Motor

REVISION:
D1

DRAWN: Justin L-E.

MATERIAL: N/A

DATE: 09-14-2024

WEIGHT: ~4.3kg

www.ebikes.ca

SURFACE FINISH: Anodized Alum

Relevant dimension drawing in mm for external use

SCALE: 1:2

Designed, Drawn and Made in Canada

DESCRIPTION:
160mm Quick Release - Santana Tandem



REFERENCE USE ONLY

THE INFORMATION CONTAINED IN THIS DRAWING IS THE SOLE PROPERTY OF GRIN TECHNOLOGIES. ANY REPRODUCTION IN PART OR AS A WHOLE WITHOUT THE WRITTEN PERMISSION OF GRIN TECHNOLOGIES IS PROHIBITED.

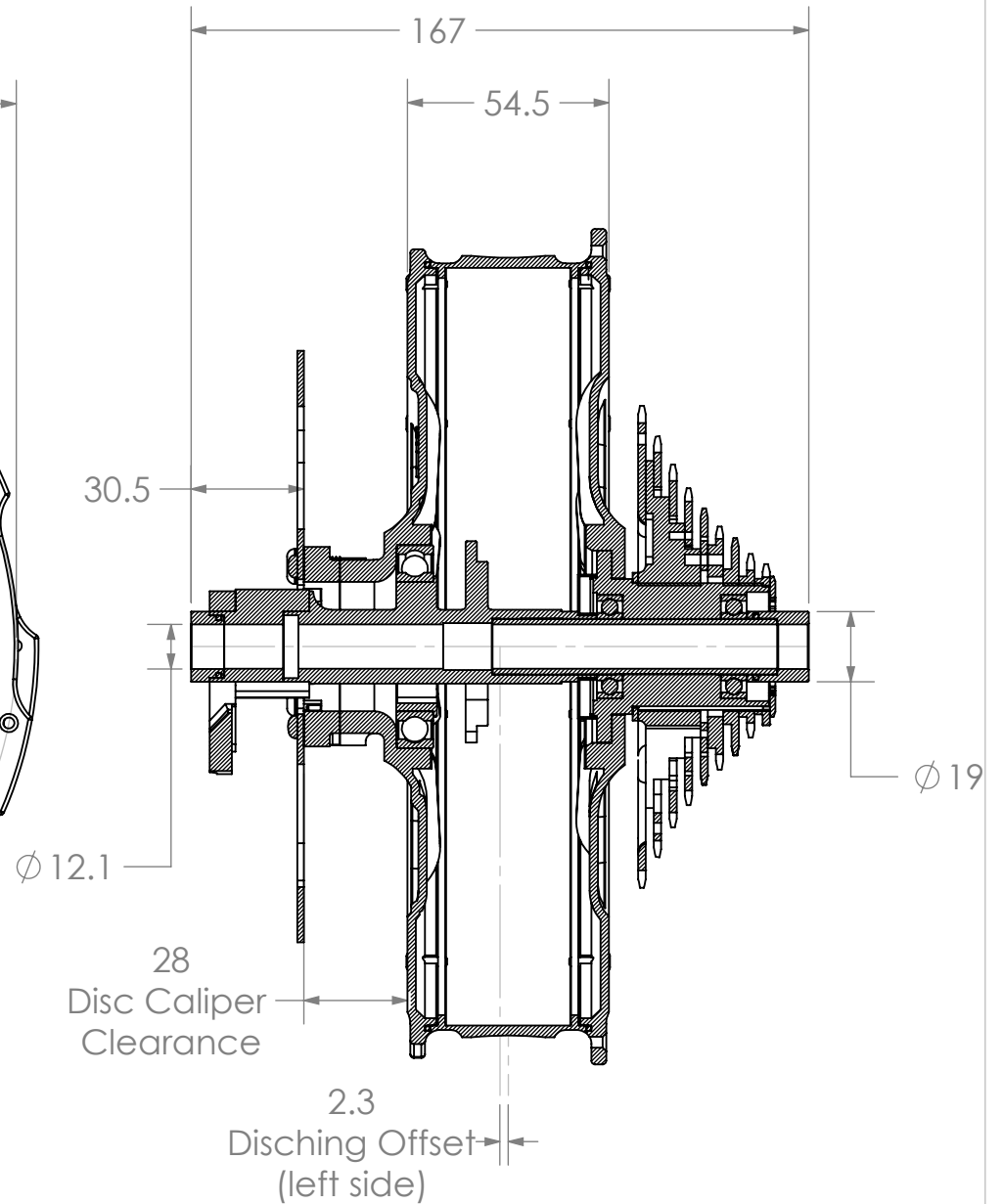
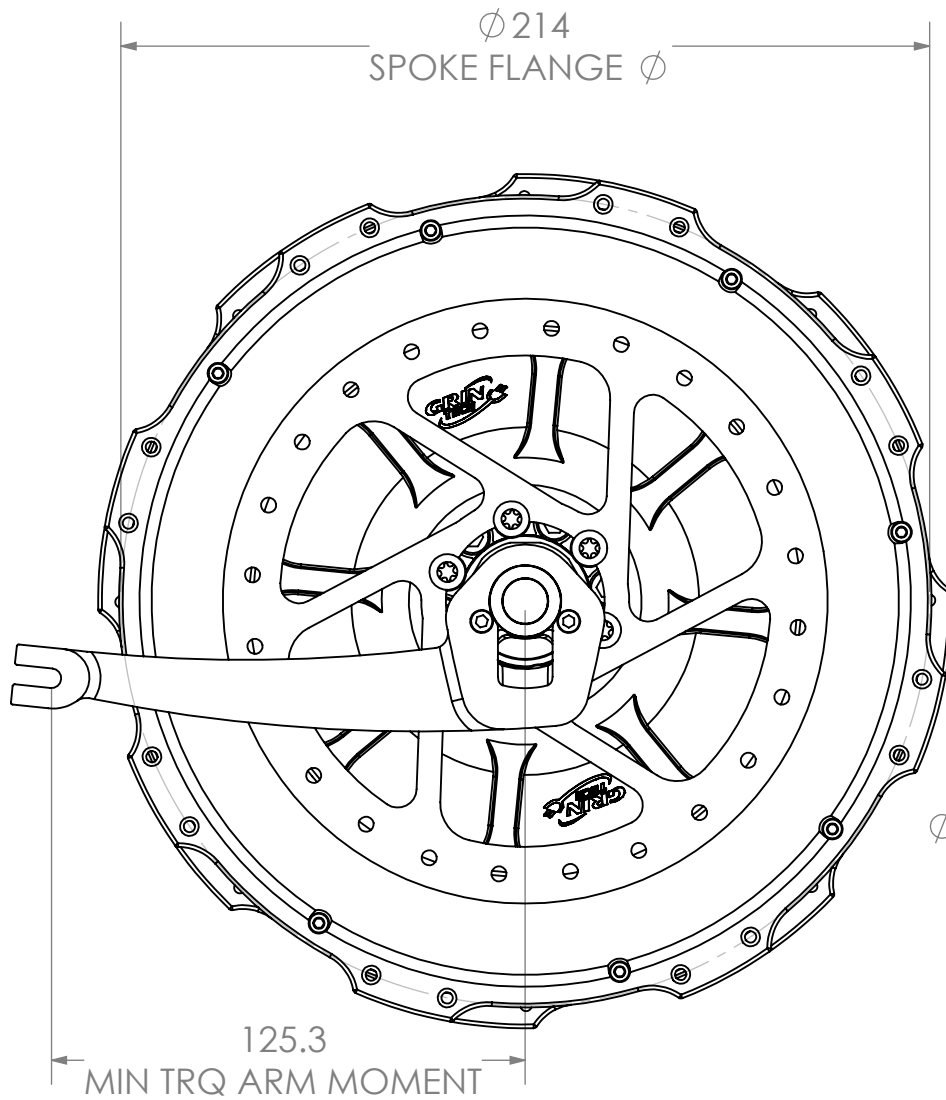

PART NO:
Grin All-Axle V3 Hub Motor

REVISION:
D1

DRAWN: Justin L-E.
DATE: 09-14-2024
www.ebikes.ca
Relevant dimension drawing in mm
for external use
Designed, Drawn and Made in
Canada

MATERIAL: N/A
WEIGHT: ~4.3kg
SURFACE FINISH: Anodized Alum
SCALE: 1:2

DESCRIPTION:
167 mm Thru Axle - Santana Tandem



REFERENCE USE ONLY
THE INFORMATION CONTAINED IN THIS
DRAWING IS THE SOLE PROPERTY OF
GRIN TECHNOLOGIES. ANY
REPRODUCTION IN PART OR AS A WHOLE
WITHOUT THE WRITTEN PERMISSION OF
GRIN TECHNOLOGIES IS
PROHIBITED.