

Gear Ratio: 29.9:1
 Magnetic Pole Pairs: 8 (239 effective)
 Connector: Higo Z910
 Thermistor: 10K NTC, B3450
 Axle End Cable Exit (Freehub Side)
 Wire Length 150mm

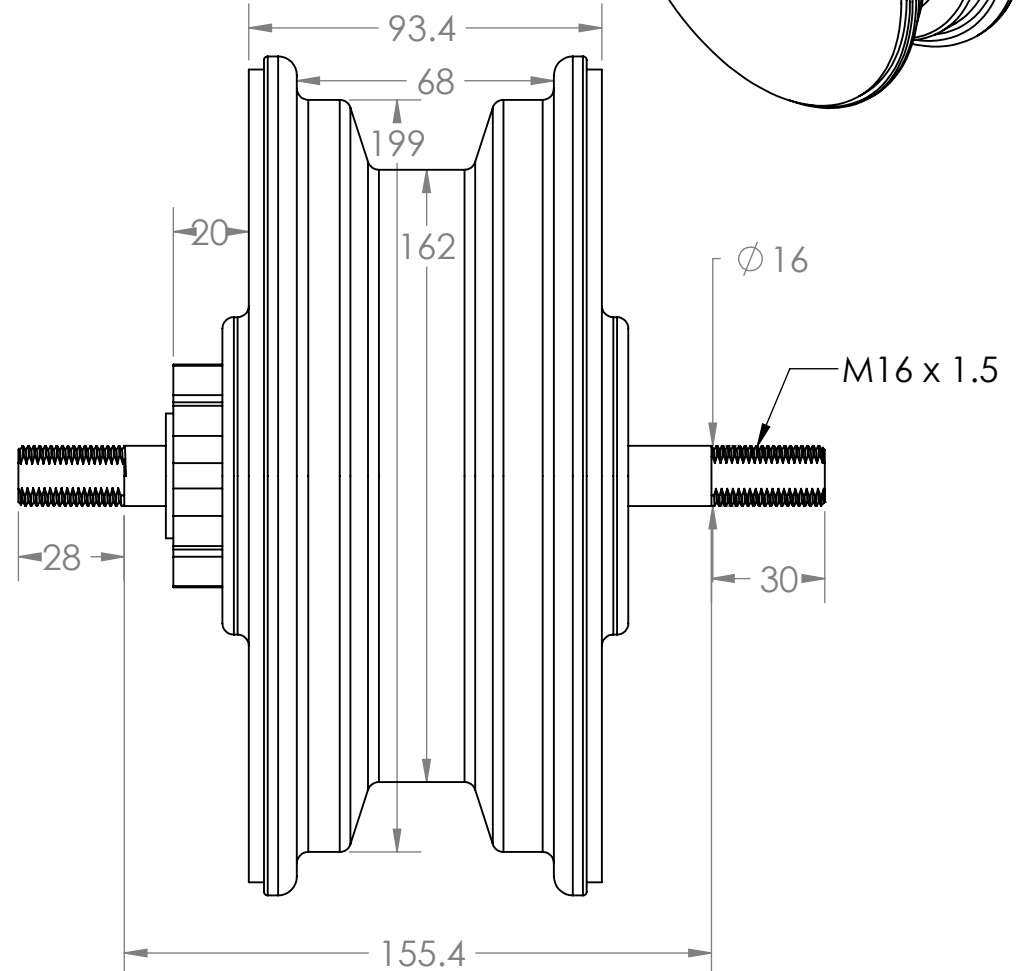
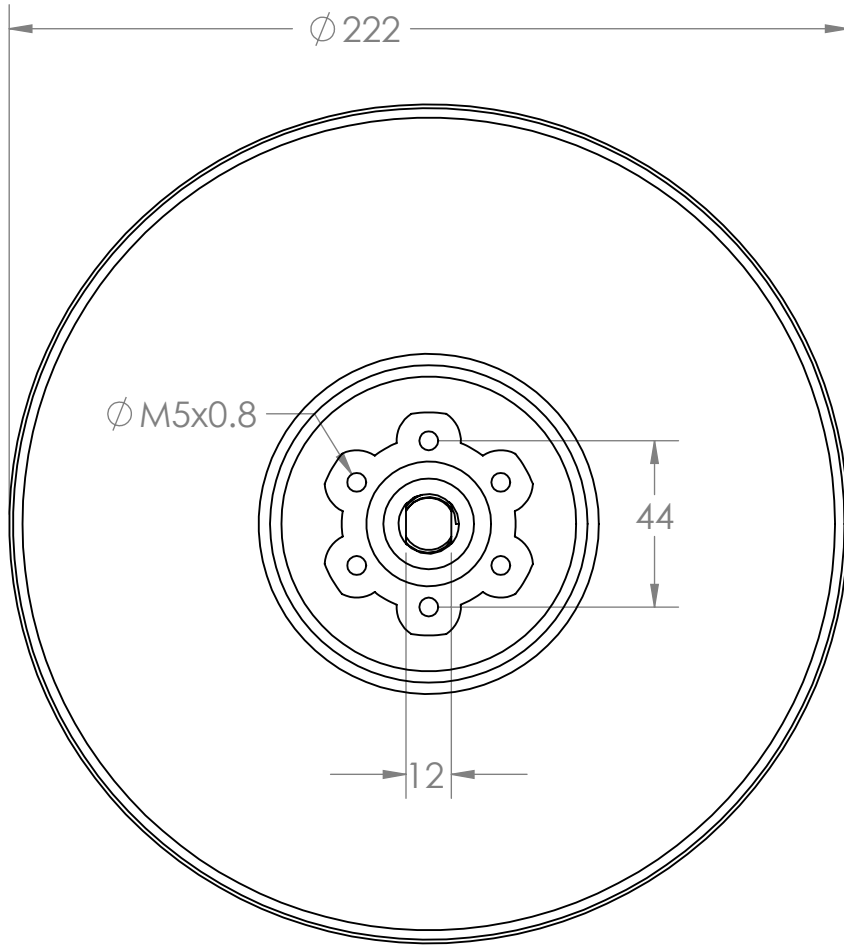
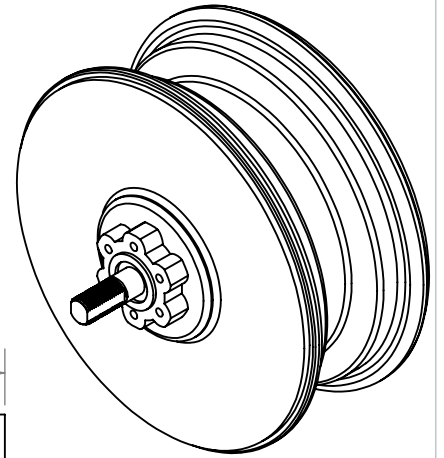

PART NO:
Bafang_WB

DESCRIPTION:
High Torque 16" Wheelbarrow Motor

REVISION:
0

DRAWN: Justin L-E
 DATE: 26/12/2019
 UNLESS OTHERWISE SPECIFIED:
 DIMENSIONS IN MM
 TOLERANCES ± 1
 TWO PLACE DECIMAL \pm

MATERIAL:
 WEIGHT:
 SURFACE FINISH:
 SCALE: **1:2**



PROPRIETARY AND CONFIDENTIAL
 THE INFORMATION CONTAINED IN THIS
 DRAWING IS THE SOLE PROPERTY OF
 GRIN TECHNOLOGIES. ANY
 REPRODUCTION IN PART OR AS A WHOLE
 WITHOUT THE WRITTEN PERMISSION OF
 GRIN TECHNOLOGIES IS
 PROHIBITED.